

# BUZZ-POLLINATED *DODECATHEON* ORIGINATED FROM WITHIN THE HETEROSTYLOUS *PRIMULA* SUBGENUS *AURICULASTRUM* (PRIMULACEAE): A SEVEN-REGION cpDNA PHYLOGENY AND ITS IMPLICATIONS FOR FLORAL EVOLUTION<sup>1</sup>

AUSTIN R. MAST,<sup>2,4</sup> DANIELLE M. S. FELLER,<sup>2,5</sup> SYLVIA KELSO,<sup>3</sup> AND ELENA CONTI<sup>2</sup>

<sup>2</sup>Institute of Systematic Botany, University of Zurich, Zollikerstrasse 107, 8008 Zurich, Switzerland; and

<sup>3</sup>Department of Biology, Colorado College, Colorado Springs, Colorado 80903 USA

We sequenced seven cpDNA regions from 70 spp. in *Dodecatheon*, *Primula* subgenus *Auriculastrum*, and outgroups, reconstructed their cpDNA phylogeny with maximum parsimony, and determined branch support with bootstrap frequencies and Bayesian posterior probabilities. Strongly supported conclusions include the (1) paraphyly of *Primula* subgenus *Auriculastrum* with respect to a monophyletic *Dodecatheon*, (2) sister relationship between the North American *Dodecatheon* and the Californian *P. suffrutescens*, (3) novel basal split in *Dodecatheon* to produce one clade with rugose and one clade with smooth anther connectives, (4) monophyly of all sections of *Primula* subgenus *Auriculastrum*, and (5) exclusion of the enigmatic *Primula* section *Amethystina* from the similar *Primula* subgenus *Auriculastrum*. These results support the origin of the monomorphic, buzz-pollinated flower of *Dodecatheon* from the heterostylous flower of *Primula*. We marshal evidence to support the novel hypothesis that the solanoid flower of *Dodecatheon* represents the fixation of recessive alleles at the heterostyly linkage group (pin phenotype). Of the remaining traits associated with their solanoid flowers, we recognize at least six likely to have arisen with the origin of *Dodecatheon*, one that preceded it (flower coloration, a transfer exaptation in *Dodecatheon*), and one that followed it (rugose anther connectives, an adaptation to buzz pollination).

**Key words:** adaptation; buzz pollination; *Cortusa*; *Dodecatheon*; exaptation; heterostyly; *Primula* subgenus *Auriculastrum*; solanoid flowers.

The nodding, often brilliantly purple and yellow, “shooting star” flowers of the largely North American genus *Dodecatheon* (15 spp. in the Primulaceae) represent to many the most familiar example of the buzz-pollination syndrome. Yet the phylogenetic context for the genus, and thus the evolutionary origins of individual floral features, has remained largely ambiguous. Here, we reconstruct the chloroplast phylogeny for *Dodecatheon* and its closest relatives in the Primulaceae and consider the evolution of floral features critical to the plant–pollinator relationship in light of the phylogeny. The hypothesis that emerges involves the co-opting of preexisting features (including one of the two floral morphologies present in the distylous ancestor), the genesis of new features with the origin

of *Dodecatheon*, and the later fine-tuning of the buzz-pollination syndrome.

During the buzz pollination of *Dodecatheon*, pollen is removed from the anthers by vibrations that originate with a settled bee’s indirect flight muscles and are transferred to the androecium via its legs and mandibles (Harder and Barclay, 1994). Pendant flowers with reflexed petals and large, conspicuous, connivent, poricidal anthers, as seen in *Dodecatheon*, were dubbed “solanoid” by Vogel (1978). Solanoid flowers are independently derived in numerous buzz-pollinated genera (Vogel, 1978; Buchmann, 1983; Faegri, 1986; Endress, 1994), including *Ardisia*, *Lysimachia*, and *Cyclamen*, three close relatives of *Dodecatheon* in the Myrsinaceae (sensu Källersjö et al., 2000).

While the solanoid flowers of *Dodecatheon* make them instantly recognizable at anthesis, sterile, pre-anthetic, and fruiting individuals of *Dodecatheon* are strikingly similar to members of *Primula* subgenus *Auriculastrum* (ca. 30 spp. from North America, Pacific coastal Asia, and Europe). Both genera have members that grow in moist alpine meadows and stream-sides, have chromosome numbers of  $2n = 44$ , and produce valvate capsules on long scapes arising from a rosette of fleshy, lance-shaped leaves with involute vernation. In an often quoted observation, Thompson (1953, p. 75) noted that *Dodecatheon jeffreyi* and *Primula parryi* are “virtually indistinguishable when the corollas and inserted anthers are removed.” Recent authors (Thompson, 1953; Wendelbo, 1961b; Richards, 1993, 2002; Holmgren, 1994) have taken this similarity as evidence for a close phylogenetic relationship between *Dodecatheon* and *Primula* subgenus *Auriculastrum* (particularly *Primula* section *Parryi*).

<sup>1</sup> Manuscript received 7 August 2003; revision accepted 22 January 2004.

The authors thank individuals and institutions who provided field assistance, leaf material, lab space and assistance, advice, and hospitality, including A. Anderberg, P. Ashby, A. Batten, B. Baldwin, M. Black, K. Chambers, J. Cole, P. Endress, T. Eriksson, P. Eveleigh, T. Forbis, N. Fujii, J. Grant, S. Hamm, N. Holmgren, D. Lang, K. Lever, A. Liston, M. Matthews, R. McBeath, R. Olmstead, C. Parker, G. Pellegrino, N. Repke, J. Richards, C. Roland, T. Rye, J. Schönenberger, I. Scott, J. Sime, F. Tahbaz, S. Wagen, B. Wessa, Y.-M. Yuan, L. Zhang, the Copenhagen Botanic Garden, Rancho Santa Ana Botanic Garden, Royal Botanic Garden Edinburgh, and Tromsø Botanic Garden. C. Hardy, R. Nyffeler, and three anonymous reviewers provided helpful comments on drafts of this paper. This work was supported by grants from the Swiss National Fund (3100-061674.00/1) and the Equal Opportunity Program of the University of Zurich to E. Conti, and the leaf material shared with us by F. Tahbaz was collected through the support of the Lawrence R. Heckard Fund of the Jepson Herbarium.

<sup>4</sup> Present address: Department of Biological Sciences, Florida State University, Tallahassee, FL 32306; E-mail: AMast@bio.fsu.edu.

<sup>5</sup> Present address: Department of Biological Sciences, Florida State University, Tallahassee, Florida 32306 USA.

This view that similarities between *Dodecatheon* and *Primula* subgenus *Auriculastrum* have shared evolutionary origins is bolstered by the results of phylogenetic analyses of cpDNA (Källersjö et al., 2000; Mast et al., 2001; Trift et al., 2002) and the internal transcribed spacers of the nuclear ribosomal DNA (Martins et al., 2003). In each of these studies, the single sampled exemplar of *Dodecatheon* is resolved as most closely related to subgenus *Auriculastrum*. In the only molecular study to date to sample each of the four sections of subgenus *Auriculastrum*, Mast et al. (2001) found weak support (66% bootstrap frequency) for an unexpected sister relationship between *Dodecatheon* and the monotypic *Primula* section *Suffrutescens* (Richards, 2002). *Primula suffrutescens*, a sub-shrubby species with wedge-shaped leaves from rock crevices and granite scree in the Sierra Nevada of California, lies close to the Pacific Northwest center of diversity for *Dodecatheon*, yet it shares fewer morphological and ecological similarities with *Dodecatheon* than does *Primula* section *Parryi*.

Unsampled in these previous molecular studies is a section of *Primula* that could modify our views on the proper circumscription of *Primula* subgenus *Auriculastrum* and thus the evolutionary context for the origin of *Dodecatheon*. This section, the Asian *Primula* section *Amethystina* (eight spp.), has fleshy, toothed leaves and globose capsules that are reminiscent of subgenus *Auriculastrum* (Smith and Fletcher, 1942). Furthermore, uncertainty remains regarding its leaf vernation, because published observations (Smith and Fletcher, 1942, 1950; Wendelbo, 1961a; sketches by J. Haldova in Halda, 1992) are conflicting and inconclusive (Mast et al., 2001). Leaf vernation has seldom changed state in *Primula* (Mast et al., 2001), and it could support the membership of section *Amethystina* in the revolute subgenus *Aleuritia*, in which it has been placed by most recent authors (Wendelbo, 1961a; Fenderson, 1986; Halda, 1992; Richards, 1993), or in the involute subgenus *Auriculastrum*, in which it was placed by Richards (2002). Inclusion of section *Amethystina* in subgenus *Auriculastrum* would bridge an existing biogeographic gap between that subgenus and the center of greatest diversity for *Primula* in the Himalayan Mountains (Mast et al., 2001).

The phylogenetic position of *Dodecatheon* within *Primula* supports a scenario in which the monomorphic, solanoid flowers of *Dodecatheon* arose from a heterostylous (specifically, distylous) ancestor. Ninety-one percent of the 430 spp. of *Primula* are distylous, as are all taxa but one (*Primula cuneifolia* subsp. *saxifragifolia*) in *Primula* subgenus *Auriculastrum* (Richards, 2002). In distylous species, populations maintain a genetic polymorphism that produces two flower morphs, each differing reciprocally in the position of their anthers and stigmas (“reciprocal herkogamy;” Webb and Lloyd, 1986). In the “pin” morph, the stigma is positioned high and the anthers low in the flower (“approach herkogamy”), whereas the reverse (“reverse herkogamy;” Webb and Lloyd, 1986) is true in the “thrum” (Darwin, 1862). Ancillary features, including pollen size and stigmatic papillae length, differ between the two morphs in *Primula* and other groups (reviewed in Dulberger, 1992). These morphological differences are often, though not always, accompanied by a sporophytically controlled incompatibility system that largely limits successful crosses to those between different morphs (“heteromorphic incompatibility;” reviewed by Barrett and Cruzan, 1994). Reciprocal herkogamy reduces pollen wastage (and thus increases male fitness), whereas heteromorphic incompatibility protects against self-fertilization and inbreeding depression (and

thus increases female fitness; Barrett, 2002). Distyly, and the functionally similar tristylly, are currently known in 28 flowering plant families (Barrett et al., 2000; Barrett, 2002).

Within *Primula*, distyly is thought to be controlled by at least three tightly linked loci (Ernst, 1925, 1936, 1957; Lewis, 1949; Dowrick, 1956), that are frequently referred to as the “heterostyly supergene” (e.g., Ganders, 1979; Barrett, 2002). The style length, stigmatic papillae length, and female mating type are thought to be controlled by locus G, the pollen size and male mating type by locus P (or two separate loci Pp and Pm, respectively; Kurian and Richards, 1997), and the anther height by locus A. Pins are homozygous recessive for these loci (gpa/gpa) and thrums are heterozygous (GPA/gpa; Bateson and Gregory, 1905; Lewis and Jones, 1992). The rarity of homozygote thrums might be due to the presence of recessive sublethal alleles linked to GPA (Kurian and Richards, 1997; Richards, 1998). The loci are likely ordered GPA, at least in *Primula* subgenus *Auriculastrum* (Kurian and Richards, 1997), based on the frequency of observed recombinations (Dowrick, 1956; Lewis and Jones, 1992; but see Charlesworth and Charlesworth, 1979).

The objectives of this study are to reconstruct the chloroplast phylogeny of *Dodecatheon* and *Primula* subgenus *Auriculastrum* and to use this to address four questions: (1) Are traditionally recognized taxa (*Dodecatheon*, *Primula* subgenus *Auriculastrum*, and sections therein) monophyletic? (2) If *Dodecatheon* is nested in *Primula*, does our increased character sampling support a sister relationship between it and the morphologically and ecologically similar *Primula* section *Parryi*? (3) Is the enigmatic, and previously unsampled, Asian *Primula* section *Amethystina* nested in the extra-Himalayan *Primula* subgenus *Auriculastrum*? (4) What new insights does the phylogeny bring to our understanding of the buildup of floral traits associated with the buzz pollination of *Dodecatheon*, including its monomorphy and the morphology of its corolla and androecium?

## MATERIAL AND METHODS

**Taxonomic sampling**—We sequenced seven cpDNA regions from 70 accessions (see Supplemental Data accompanying the online version of this article). These represent 22 of the 30 commonly recognized taxa of *Dodecatheon*, all taxa from three of the four sections of *Primula* subgenus *Auriculastrum* (sections *Suffrutescens*, *Cuneifolia*, and *Parryi*), five of the six series (as recognized by Zhang, 2002) of the remaining section *Auricula*, two species from the enigmatic section *Amethystina*, and the other major clades of *Primula*. Mast et al. (2001) defined *Primula* as all descendents of the most recent common ancestor (MRCA) of genus *Primula* using the “clademark” convention of Baum et al. (1998a). In addition, we sequenced the *matK* gene in five additional genera of the Primulaceae that are outside of *Primula*; we did not expand the taxonomic sampling for the six noncoding datasets to minimize the number of alignment-ambiguous positions in them. Prior cpDNA studies (Källersjö et al., 2000; Mast et al., 2001; Trift et al., 2002) strongly support the position of two of these five additional genera (*Androsace* and *Douglasia*) as sister to the remaining sampled taxa in the Primulaceae. Consequently, we used these two genera for outgroup comparisons in the analysis of our *matK* data set. We present the results that include only the 70 taxa in *Primula* with a basal trichotomy, as supported by the results of Mast et al. (2001).

**DNA extraction, amplification, and sequencing**—We extracted total genomic DNA from 20–30 mg of fresh leaf material (dried mass after lyophilization), silica-dried material, or herbarium material. Fresh material was lyophilized for 24–48 h in a Lyovac GT 2 (Leybold Vacuum, Cologne, Ger-

many). Dry leaf tissue was disrupted with glass beads using a Retsch MM 2000 shaker (Retsch, Haan, Germany) at an amplitude of 80 for 2 min. We used the DNeasy Plant Mini kit (Qiagen, Valencia, California, USA) for fresh and silica-dried material and an SDS extraction protocol (Eichenberger et al., 2000) for herbarium material.

Each DNA region was amplified using the polymerase chain reaction (PCR; Mullis and Faloona, 1987): the *matK* gene with primers 1F and 1R of Sang et al. (1997), the *rpl16* intron with primers F71 of Jordan et al. (1996) and R1516 of Baum et al. (1998a), the *rps16* intron with primers F and R2 of Oxelman et al. (1997), the *trnL* intron and *trnL/F* spacer with primers c and f of Taberlet et al. (1991), the *trnS/G* spacer with primers trnS(GCU) and trnG(UCC) of Hamilton (1999), and the *trnT/L* spacer with primers a and b of Taberlet et al. (1991). The most effective thermal cycling program proved to be 34 cycles of 0.5 min at 95°C, 1 min at 52°C, and 1.7 min at 72°C, with a terminal extension of 10 min at 72°C. A TGradient thermocycler (Whatman Biometra, Göttingen, Germany) performed all PCR reactions. To detect successfully amplified DNA and the possible contamination of negative controls, we examined PCR products on agarose gels. We purified successful PCR reactions with the QIAquick PCR purification kit (Qiagen).

A Gene Amp PCR system 9700 (Perkin Elmer, Boston, Massachusetts, USA) performed cycle-sequencing reactions that we prepared with the ABI PRISM dye terminator cycle sequencing ready reaction kit (Perkin Elmer). The primers used in the sequencing reactions were the same as in the amplifications with the addition of the internal *matK* primer 3F (Sang et al., 1997). We cleaned the sequenced products with microspin G-50 columns (Amersham Biosciences, Piscataway, New Jersey, USA) or 96-well multiscreen filtration plates (Millipore, Billerica, Massachusetts, USA) to remove excess dye terminators before we ran them out on an ABI Prism 377 or 3100 DNA sequencer (Perkin Elmer). To detect mistakes and correct uncertainties in the computer-generated sequence, we compared aligned trace-files in Sequencher 3.0 (Gene Codes Corporation, Ann Arbor, Michigan, USA).

**Defining substitution and indel characters**—We reviewed each variable position in the alignment twice in Sequencher 3.0 to confirm that base calls were consistent at informative positions. In the six noncoding regions, nucleotide (nt) substitutions and insertion and/or deletion (indel) events occasionally combined to produce a region that could be aligned reasonably in more than one way. This occurred most frequently when poly-N stretches of variable length were embedded with variant nts. We segregated the nts in those regions and in regions where two or more nonidentical insertions arose independently into invariant alignment positions with gaps so that informative characters were not produced. In the alignment of the *matK* gene, we inserted gaps in multiples of three in positions that maintained the reading frame. The aligned matrices are available at TreeBase ([www.treebase.org](http://www.treebase.org)).

We determined the borders of each region for comparisons with the complete cpDNA sequence of *Nicotiana tabacum* (GenBank accession NC\_001879). Each data set represents the complete sequence for each region and does not include portions of adjacent regions, with one exception. The *rpl16* intron data set is missing 50 nts on the 5' end of the intron due to the position of the priming site.

We coded indels as additional characters for maximum parsimony (MP) analyses if they were informative, bordered by stretches of unambiguously aligned nts, and could be described as binary (presence/absence) characters. We coded insertions as the same state if they were the same size and identical ( $\leq 2$  nts long) or had no more than one nt substitution ( $> 2$  nts long) and did not appear to be duplications of different parts of the adjacent sequence. We did not code single-nt indels if they were adjacent to strings ( $> 1$  nt long) of the same nt (e.g., AAA vs. AAAA). Other researchers have also excluded this type of indel because it may arise from experimental error (Downie et al., 1998; McDade and Moody, 1999), or they have noted its evolutionary lability (Small et al., 1998). When taxa had long deletions that stretched over positions containing coded indels, we coded those taxa as uncertain for the intervening indels.

**Phylogenetic reconstruction**—We used the MP optimality criterion to reconstruct the chloroplast phylogeny of the 70 intensively sampled taxa with

each of the six noncoding regions separately and with these six together in combination with the *matK* gene. We also used MP to reconstruct the chloroplast phylogeny for these 70 taxa plus the five additional genera sampled in the *matK* data set. PAUP\* 4.0b10 (Swofford, 2002) performed all MP calculations. For the MP analyses and the calculation of the consistency index (CI; Kluge and Farris, 1969) and the retention index (RI; Farris, 1989), we included only informative nt and indel characters and weighted all of the characters and character state transitions equally. The heuristic MP searches employed 10 random addition sequences and tree bisection-reconnection (TBR) branch swapping.

To ascertain the degree of support for branches in the shortest MP trees of the 70-taxa, seven-region analysis and the 75-taxa, *matK* analysis, we used PAUP\* 4.0b10 to calculate nonparametric bootstrap frequencies (Felsenstein, 1985) in 1000 replicates. The MP analyses of each replicate employed 10 random addition sequences and TBR branch swapping with the maximum number of saved trees per replicate set at 5000.

To further ascertain the degree of support for branches in the shortest MP trees of the 75-taxa, *matK* analysis, we calculated Bayesian posterior probabilities with Mr. Bayes 3.0b4 (Huelsenbeck and Ronquist, 2001). We used hierarchical likelihood ratio tests (hLRTs) and the Akaike Information criterion (AIC) in MrModeltest 1.1b (J. A. A. Nylander, Department of Systematic Zoology, Uppsala University, Sweden, unpublished program) to choose the adequately parameter-rich model of sequence evolution for the *matK* gene from among 24 models. MrModeltest is a simplified version of Posada and Crandall's (1998) Modeltest 3.06 that only considers those models that can be implemented in Mr. Bayes. We used the chosen model for the maximum likelihood (ML) calculations involved in hypothesis testing as well.

For the Bayesian analysis, Mr. Bayes 3.0b4 ran one cold and three heated chains for  $1 \times 10^6$  generations in a Markov Chain Monte Carlo (MCMC). Mr. Bayes sampled the cold chain of the MCMC every 1000th generation, and we plotted the likelihood values of these sampled trees in Microsoft Excel to determine the point at which the chain reached stationarity. In PAUP\* 4b10, we constructed a majority rule consensus of the trees sampled following this initial "burn-in" period to determine posterior probabilities for the internal branches. Mr. Bayes performed two separate MCMC runs using these settings, and we compared the posterior probabilities calculated with each of them.

**Hypothesis testing**—We tested the significance of the evidence against prior hypotheses that were not supported by the cpDNA data in an MP framework using the winning sites test (WS; Prager and Wilson, 1988) and in a ML framework using the Shimodaira-Hasegawa test (SH; Shimodaira and Hasegawa, 1999). We used the WS test for both the 70-taxa, seven-region data set and the 75-taxa, *matK* data set, but we used the SH test only with the 75-taxa, *matK* data set. For the tests, we compared a randomly chosen tree found in an unconstrained MP search with a randomly chosen tree found in an MP search constrained to recover the feature of interest. PAUP\* 4b10 performed the MP searches as described with the exception that the constrained searches involved 100 (rather than 10) random addition sequences. We included only parsimony informative nt and indel characters in the constrained and unconstrained MP searches and in the WS test, but we included all aligned nt positions (and only nts) for the SH test. For the one-tailed SH test, PAUP\* 4b10 used a distribution derived from 1000 resampling estimated log-likelihood bootstrap replicates.

**Pollen size measurements**—We collected pre-anthetic flowers of *Dodecatheon alpinum* subsp. *majus* (Feller & Mast 592; all vouchers in Z), *D. frigidum* (Feller & Mast 531), *D. pulchellum* subsp. *pulchellum* var. *alaskanum* (Feller & Mast 510), *Primula suffrutescens* (thrum and pin; Feller & Mast 577), and *P. cuneifolia* subsp. *saxifragifolia* (Feller & Mast 500) in FAA. After one month, we transferred the material to 70% ethanol. For each taxon or flower morphology, we measured the size of 100 pollen grains from one individual along the longest axis using an optical micrometer at 400 $\times$  magnification. With the exception of the ellipsoidal pollen of *Dodecatheon alpinum* subsp. *majus*, the taxa have nearly spherical pollen grains (Wendelbo, 1961b).

TABLE 1. DNA character descriptions. The ratio of transition to transversion substitutions (Ti : Tv) was estimated by maximum likelihood using the substitution model of Hasegawa et al. (1985) on one of the shortest MP trees for each region or the combined regions. Distance calculations were made in the same way. Two sets of values are reported here for the *matK* gene, one that includes taxa from outside *Primula* ("expanded") and one that does not. The ingroup consists of *Dodecatheon* and *Primula* subgenus *Auriculastrum*.

Region	Range of sequence lengths	Aligned length	Informative nt <sup>a</sup> positions (% of aligned positions)	Informative indels	Ti : Tv	Sequence distance within ingroup (incl. outgroup)
<i>matK</i> gene (expanded)	1521–1539	1581	320 (20.2%)	7	3.3 : 1	0–2.4 (12.2%)
<i>matK</i> gene	1521–1539	1569	256 (16.3%)	6	3.6 : 1	0–2.4 (9.1%)
<i>rpl16</i> intron	745–992	1133	141 (12.4%)	7	2.5 : 1	0–4.1 (8.4%)
<i>rps16</i> intron	730–851	989	107 (10.8%)	5	3.4 : 1	0–2.5 (7.0%)
<i>trnL</i> intron	419–540	613	44 (7.2%)	6	1.7 : 1	0–1.7 (5.9%)
<i>trnL/F</i> spacer	360–407	499	80 (16.0%)	5	3.4 : 1	0–3.8 (14.5%)
<i>trnS/G</i> spacer	474–709	916	121 (13.2%)	6	2.5 : 1	0–3.6 (9.7%)
<i>trnT/L</i> spacer	772–866	1028	127 (12.4%)	10	1.9 : 1	0–3.0 (9.4%)
Seven regions combined		6747	876 (13.0%)	45	2.5 : 1	0–2.4 (7.8%)

<sup>a</sup> nt = nucleotide.

## RESULTS

**Defining substitution and indel characters**—We provide descriptions of the seven sampled cpDNA regions in Table 1. The aligned length of the combined seven-region data set for the 70 intensively sampled taxa is 6747 positions, with the range for any single data set from 499 (*trnL/F* spacer) to 1569 (*matK*) positions. The length of the *matK* data set is increased by 12 positions when the five additional outgroup taxa are aligned with it. Of these 6747 positions, 13% provided parsimony-informative character state distributions, with the range for any single data set from 7.2% (*trnL* intron) to 16.3% (*matK*).

We defined 46 indel characters for the data set (Tables 1 and 2); one of these (A6 in *matK*) is only informative when the five additional outgroup taxa are included. Fitch (1971) parsimony, using the topologies of Figs. 1 and 3, reconstructs 25 of these (54%) as insertions, 17 (37%) as deletions, three as either insertions or deletions (depending upon the resolution of the basal trichotomy in *Primula*), and one as an insertion that is later deleted. Of the 47 indels, eight (17%) are homoplasious on Figs. 1 or 3.

The data sets are complete with the following exceptions: (1) *P. marginata* is missing data for 99 positions at the 5' end of the *matK* gene, (2) *Primula glutinosa* (Tromsø Botanic Garden acc.) is missing data for 79 positions at the 3' end of the *rpl16* intron, (3) all the outgroup taxa but *P. forbesii* are missing data for nine positions at the 5' end of the *rps16* intron, (4) *P. parryi* (A. R. Mast acc.) and *P. cusickiana* subsp. *domensis* are missing data for 22 positions at the 5' end of the *trnL* intron, (5) *Dodecatheon hendersonii* subsp. *cruciatum*, *D. hansenii*, and *D. redolens* are missing data for all positions of the *trnT/L* spacer, and (6) *P. forbesii* is missing data for 104 positions at the 3' end of the *trnT/L* spacer.

**Phylogenetic reconstructions**—The strict consensus of the 28 shortest MP trees found for the 75-taxon sampling of *matK* data is shown in Fig. 1 with the tree statistics. *Primula* is resolved as monophyletic in the strict consensus (98% bootstrap frequency and 100% posterior probability), as is the clade composed of *Primula* subgenus *Auriculastrum* and *Dodecatheon* (100% bootstrap frequency and 100% posterior probability). Of the 47 branches resolved in this strict consensus, 35 (74%) have strong bootstrap support (frequency greater than 70%). The frequency range is 54–100%, and the mean is 85%.

MrModeltest 1.1b chose the SYM substitution model (Zharikh, 1994) as adequately parameter-rich using both the hLRT and AIC approaches. The two separate MCMC runs by Mr. Bayes 3.0b4 with the 75-taxon sampling of *matK* and the SYM substitution model each appeared to reach stationarity after 25 000 generations (further significant changes in the likelihood score beyond  $1 \times 10^6$  generations cannot be ruled out), and thus we excluded the first 26 sampled trees. PAUP\*4.0b10 calculated the majority rule consensus of the remaining 975 trees for each run, and we took the frequency of the branches in these consensus as their posterior probabilities. The posterior probabilities for 43 of 47 branches were identical in each of the two MCMC runs and only differed by 1% for the four remaining branches. The posterior probabilities calculated in the first MCMC run are shown beneath the branches in Fig. 1. The range of posterior probabilities for the branches resolved in the strict consensus of the shortest MP trees is 85–100%, and the mean is 99%.

The strict consensus of the shortest MP trees found when analyzing each of the six noncoding regions separately are shown in Fig. 2 with the tree statistics. The ranges of CI values (0.716–0.794) and RI values (0.889–0.938) are similar across the individual analyses. Only seven of the branches (marked with an asterisk in Fig. 2; three in the *trnL* intron consensus and four in the *trnL/F* spacer consensus) are incongruent with the topology found in the strict consensus for the combined seven-region data set (Fig. 3). Because chloroplast inheritance is predominantly uniparental in angiosperms (Corriveau and Coleman, 1988; Harris and Ingram, 1991; Morgenson, 1996) and recombination is rare when biparental inheritance does occur (Birky, 1995), the entire cpDNA is expected to have a shared history. Thus, we ascribe the minor incongruence observed to homoplasy amongst the small number of parsimony-informative characters in the *trnL* intron and *trnL/F* spacer (50 and 85 characters, respectively, vs. 112–327 characters in any of the remaining regions; Table 1).

The MP analysis of the combined seven-region data set for the 70 intensively sampled taxa found 76 shortest trees. The strict consensus of these trees and the tree statistics are shown in Fig. 3. Of the 56 branches resolved in this strict consensus, 50 (89%) have strong bootstrap support (frequency range = 37–100%, mean = 92%). Individual features of the strict consensus trees depicted in Figs. 1 and 3 are discussed further.

**Hypothesis testing**—We used the SH and WS tests to determine whether or not the cpDNA data significantly rejected

TABLE 2. Indel characters. The alpha-numeric character code is used when mapping indel character changes onto the strict consensus tree for the combined data. The length of each insertion is the number of nucleotides present; the length of each deletion is the number of aligned positions involved. An indel is characterized as "I or D" if it occurs at the base of one of the clades involved in the basal trichotomy in *Primula*; it is characterized as "I and D" if it is homoplasious in this way. Indel events were reconstructed using Fitch parsimony on Figs. 1 and 3.

Region	Code	Starting position	Length	Insertion (I) or deletion (D)
<i>matK</i> gene	A1	37	6	I
	A2	106	3	I
	A3	154	3	I
	A4	205	12	D
	A5	223	6	I
	A6	382	6	I
	A7	820	6	D
<i>rp116</i> intron	B1	136	6	I
	B2	285	5	I
	B3	297	8	D
	B4	347	5	I
	B5	450	9	D
	B6	650	5	I or D
	B7	726	290	D
<i>rps16</i> intron	C1	243	1	I
	C2	370	2	D
	C3	377	14	I
	C4	512	8	D
	C5	598	3	I or D
<i>trnL</i> intron	D1	210	116	D
	D2	250	5	I
	D3	257	1	I
	D4	279	6	I
	D5	294	8	I
	D6	489	6	I
<i>trnL/F</i> spacer	E1	101	6	I
	E2	237	9	D
	E3	280	3	D
	E4	376	4	I
	E5	410	19	I and D
<i>trnS/G</i> spacer	F1	86	8	D
	F2	362	12	D
	F3	430	4	I
	F4	457	270	D
	F5	494	5	I
	F6	760	10	D
<i>trnT/L</i> spacer	G1	24	11	D
	G2	27	1	I
	G3	120	5	I
	G4	203	1	I
	G5	374	2	I or D
	G6	380	4	I
	G7	404	1	I
	G8	421	30	D
	G9	557	5	I
	G10	708	13	D

four topologies: (1) *Dodecatheon* sister to *Primula*, (2) *Primula* section *Amethystina* sister to the clade composed of *Primula* subgenus *Auriculastrum* and *Dodecatheon*, (3) *Primula* section *Parryi* sister to *Dodecatheon*, and (4) a monophyletic *Dodecatheon* section *Purpureo-tubulosa*. We considered the first topology listed above solely with the expanded 75-taxa, *matK* data set. All of the alternative topologies but one are rejected in all of the tests at  $P \leq 0.05$ . The one that is not rejected in any of the tests at this threshold is *Primula* section *Parryi* sister to *Dodecatheon*. However, it comes close to the threshold in two of the three tests ( $P = 0.054$  and  $0.0654$ ;

Table 3). The high  $P$  value (0.5000) for the test of this topology using the WS test on the expanded *matK* data set is due to the small number of characters (just two) relevant to the test.

**Pollen size**—The pollen of the long homostyle *Primula cuneifolia* subsp. *saxifragifolia* (mean =  $19.4 \mu\text{m}$ , SD =  $1.2 \mu\text{m}$ , range =  $16\text{--}22 \mu\text{m}$ ; Fig. 4) is similar in size to the thrum pollen of *P. suffrutescens* (mean =  $16.9 \mu\text{m}$ , SD =  $1.1 \mu\text{m}$ , range =  $15\text{--}20 \mu\text{m}$ ). Pollen in *D. frigidum* (mean =  $10.6 \mu\text{m}$ , SD =  $0.5 \mu\text{m}$ , range =  $10\text{--}12 \mu\text{m}$ ) and *D. pulchellum* subsp. *pulchellum* var. *alaskanum* (mean =  $12.8 \mu\text{m}$ , SD =  $1.0 \mu\text{m}$ , range =  $12\text{--}14 \mu\text{m}$ ) are similar in size to the pin pollen of *P. suffrutescens* (mean =  $12.8 \mu\text{m}$ , SD =  $1.1 \mu\text{m}$ , range =  $10\text{--}15 \mu\text{m}$ ). The ellipsoidal pollen of *D. alpinum* subsp. *majus* (mean =  $20.9 \mu\text{m}$ , SD =  $1.0 \mu\text{m}$ , range =  $20\text{--}24 \mu\text{m}$ ) is longer than the diameter of the nearly spherical thrum pollen of *P. suffrutescens*. Our measurements of pollen size in *Dodecatheon* are similar to those reported by Wendelbo (1961b; Fig. 4). Differences between his and our measurements might be explained by slight pollen swelling in glycerol jelly, which he used (Wendelbo, 1961b; Moore et al., 1991), and/or slight pollen shrinkage in 70% ethanol, which we used. These might be the reasons for his larger size measurement of *D. frigidum* ( $15 \mu\text{m}$ ; Fig. 4), though his measurement of *D. alpinum* is low within the range we observed for that species.

## DISCUSSION

***Dodecatheon* is nested in *Primula* subgenus *Auriculastrum***—Most modern taxonomic treatments of *Dodecatheon* (Thompson, 1953; Wendelbo, 1961b) and *Primula* (Richards, 1993, 2002), as well as all previous molecular phylogenetic studies that sampled both genera using cpDNA (Källersjö et al., 2000; Mast et al., 2001; Trift et al., 2002) or nuclear DNA (Martins et al., 2003) characters, have supported a close relationship of *Dodecatheon* to *Primula* subgenus *Auriculastrum*. The current cpDNA data set (ca. 6.8 kb) is the largest sampling of molecular characters and the most complete sampling of taxa in *Dodecatheon* and *Primula* subgenus *Auriculastrum* to date. It significantly rejects the divergence of *Dodecatheon* prior to the MRCA of *Primula* (Table 3), and it strongly supports *Dodecatheon* as a descendent of the MRCA of *Primula* subgenus *Auriculastrum* (high posterior probabilities of Fig. 1 and high bootstrap frequencies of Fig. 3). This has significant implications for the evolution of the solanoid, buzz-pollinated flowers of *Dodecatheon*. We will discuss this at length after a consideration of the additional phylogenetic relationships reconstructed here (Figs. 1 and 3). Transfer of the species of *Dodecatheon* to their own section in *Primula* subgenus *Auriculastrum* merits consideration, but it will be discussed elsewhere.

**Phylogenetic relationships in *Dodecatheon***—The monophyly of *Dodecatheon* is strongly supported in the cpDNA phylogeny (100% posterior probability, Fig. 1; 97% bootstrap frequency, Fig. 3), and previous suggestions to the contrary are unknown in the literature. In contrast, the basal split in *Dodecatheon* that leaves *Dodecatheon* section *Purpureo-tubulosa* paraphyletic is novel and has not been previously suggested. However, with the one exception discussed later (the putative allopolyploid *D. poeticum*), it cleanly splits the genus into a clade with rugose anther connectives and a clade with

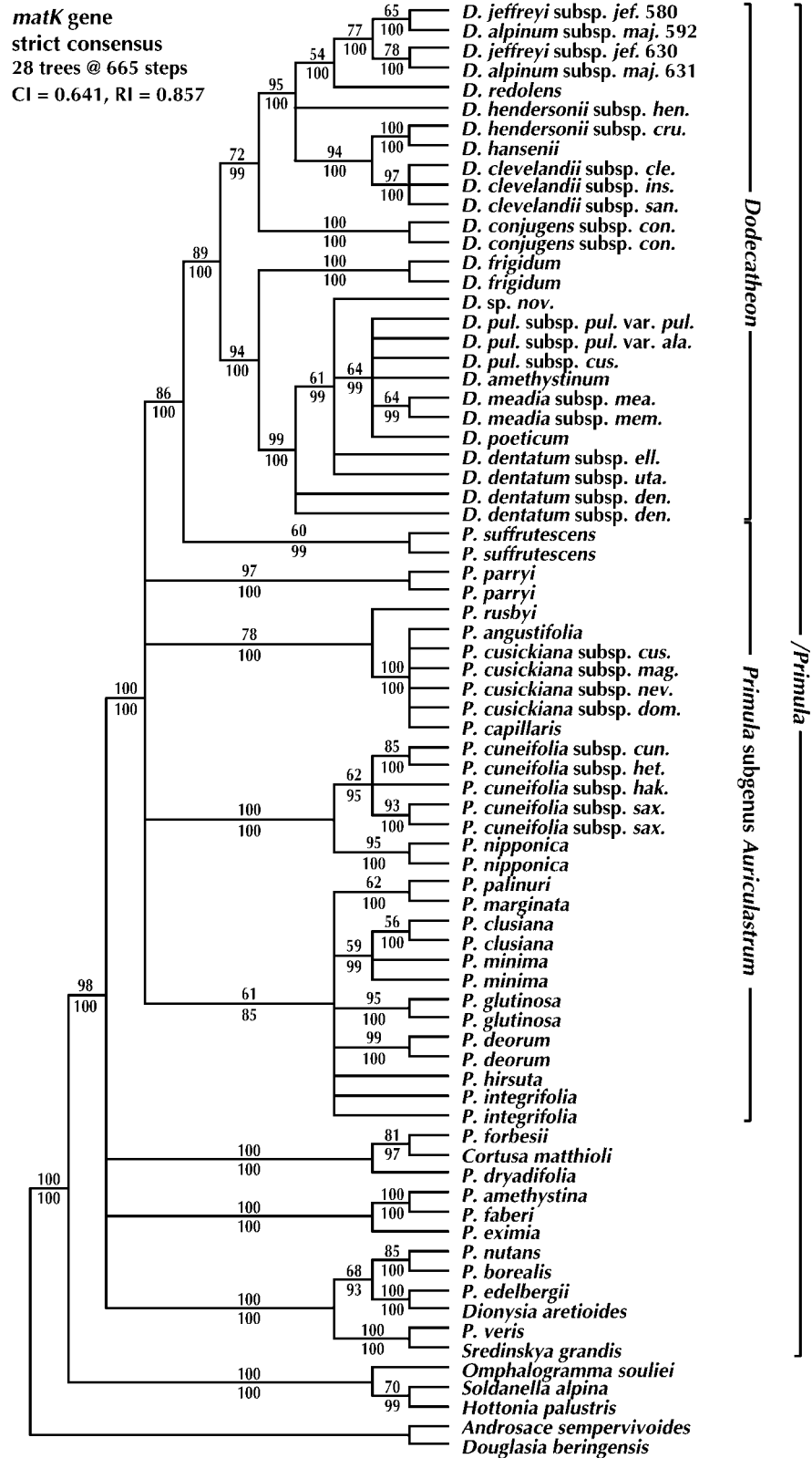

Fig. 1. Strict consensus of 28 shortest trees found for *Dodecatheon* and *Primula* subgenus *Auriculastrum* when the *matK* data set with an expanded outgroup sampling is analyzed using maximum parsimony. Tree statistics are given above the consensus tree. Bootstrap frequencies (as a percentage) are given above the branches; Bayesian posterior probabilities (as a percentage) are given below the branches. Taxonomic membership in genus *Dodecatheon*, *Primula* subgenus *Auriculastrum*, and *Primula* (see definition in Materials and Methods: Taxonomic sampling) shown to the right of the tree. CI, consistency index; RI, retention index.

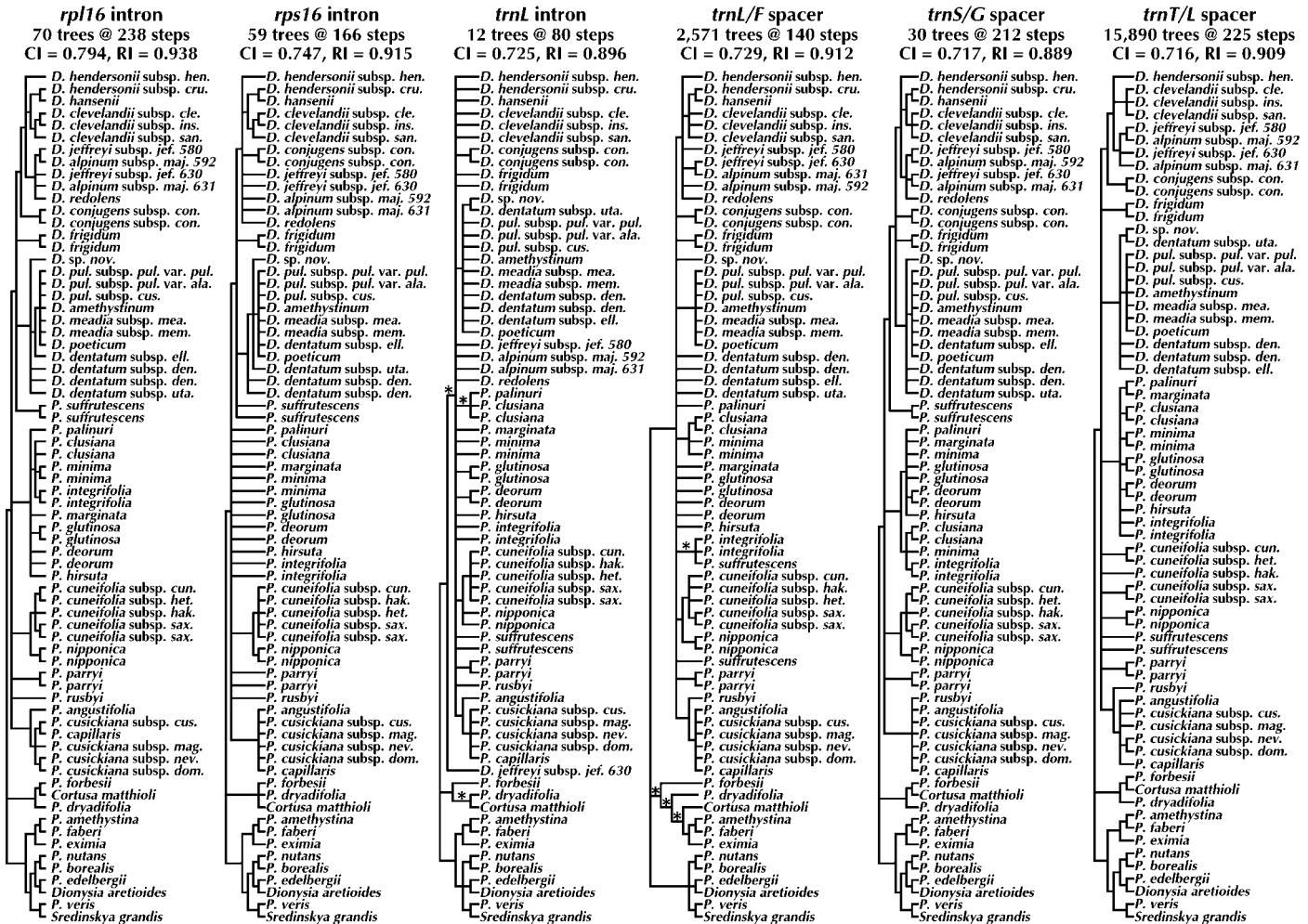

Fig. 2. Strict consensus trees of the shortest trees found for *Dodecatheon* and *Primula* subgenus *Auriculastrum* when each of the six noncoding data sets with a reduced outgroup sampling are analyzed separately using maximum parsimony. Tree statistics are given above each consensus tree. Branches that conflict with the strict consensus of the shortest trees found when the all seven data sets are analyzed in combination (Fig. 3) are designated with an asterisk.

smooth connectives (Figs. 4 and 5). Smooth connectives in *Primula* (Fig. 5) support the rugose state as the derived condition and thus the monophyly of the former clade. We are as yet unaware of any morphological synapomorphies supporting the monophyly of the clade with smooth connectives, but the support for it in the cpDNA results is high (100% posterior probability, Fig. 1; 89% bootstrap frequency, Fig. 3).

The basal split in the cpDNA phylogeny of *Dodecatheon* leaves *Dodecatheon* section *Purpureo-tubulosa* paraphyletic with respect to the other two monophyletic sections (Fig. 3), and the cpDNA data significantly rejects the monophyly of section *Purpureo-tubulosa* (Table 3). Thompson (1953), who circumscribed the three sections of *Dodecatheon*, noted that anther connective rugosity is useful taxonomically in *Dodecatheon*, but he maintained the section *Purpureo-tubulosa* as an assemblage with both smooth and rugose anthers because of the operculate capsules and similar seedling development of its members. The other sections of *Dodecatheon* (Thompson, 1953) and the species of *Primula* subgenus *Auriculastrum* (Richards, 2002) have valvate capsules, and thus the operculate character state appears to provide a synapomorphy for *Dodecatheon* section *Purpureo-tubulosa*, in conflict with an-

ther connective rugosity and the cpDNA phylogeny. We have not examined seedling development in closely related species of *Primula*, and thus we cannot comment on the polarity of this character and its implications for the monophyly of section *Purpureo-tubulosa*.

In his extensive biosystematic study of *Dodecatheon*, Thompson (1953) split section *Purpureo-tubulosa* into two groups, one that might prove to be monophyletic with further character sampling (the *Dodecatheon hendersonii* complex) and one that is not monophyletic in the cpDNA phylogeny (the *Dodecatheon frigidum* complex; Fig. 3). He did this primarily based on the presence or absence of a well-developed filament tube and the species' geographic distributions. Species of the *Dodecatheon hendersonii* complex (four spp.; *D. subalpinum* is unsampled here) possess a well-developed filament tube (as do other taxa in both of the major clades of *Dodecatheon*), and their Pacific coastal distributions overlap in central California (Thompson, 1953; Cholewa and Henderson, 1993). In the combined cpDNA phylogeny (Fig. 3), *D. hendersonii* subsp. *hendersonii* is in a trichotomy with a clade composed of the remaining, sampled members of the *D. hendersonii* complex and with the monophyletic section *Capitu-*

7 cpDNA regions  
 strict consensus  
 76 trees @ 1497 steps  
 CI = 0.734, RI = 0.911

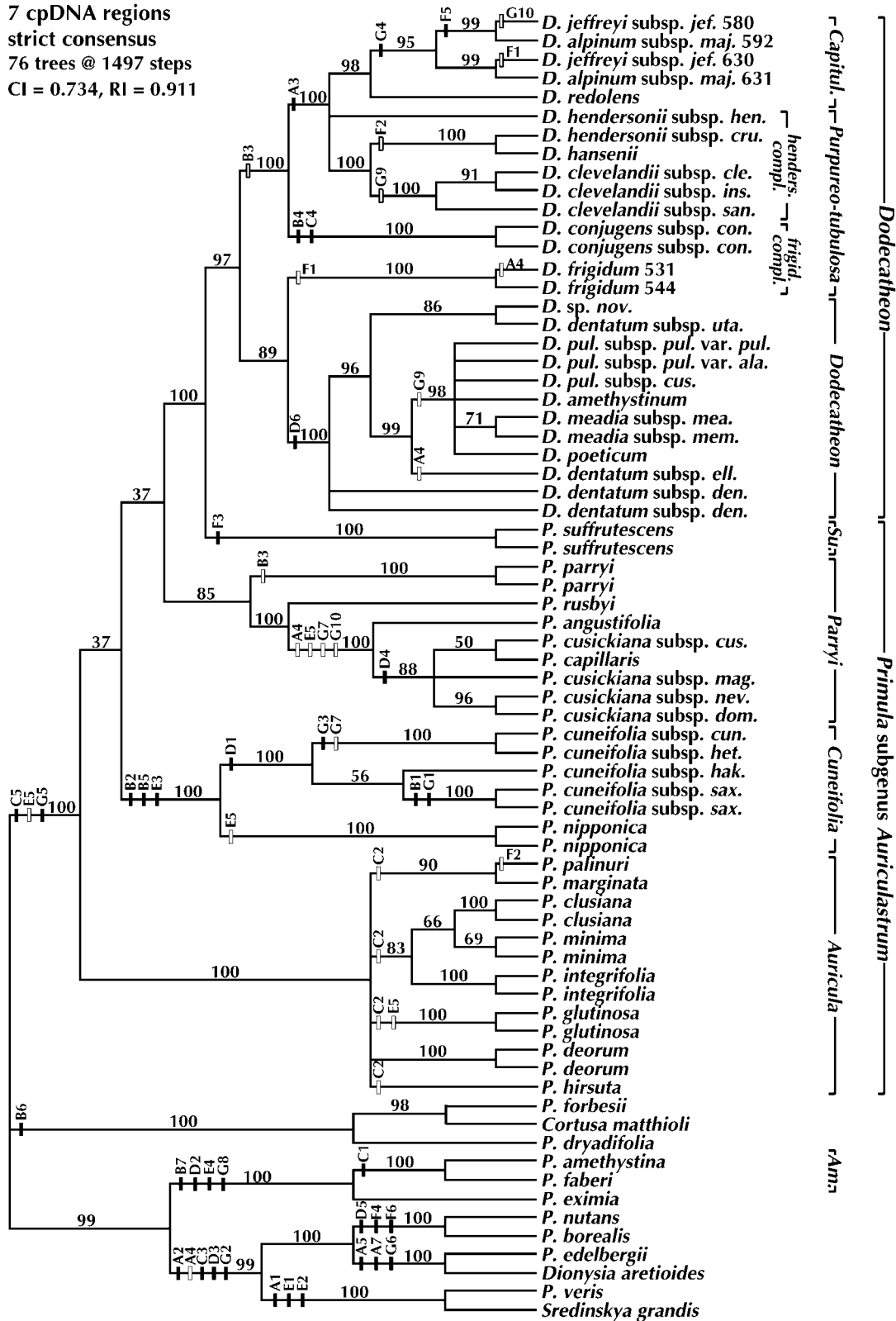

Fig. 3. Strict consensus of 76 shortest trees found for *Dodecatheon* and *Primula* subgenus *Auriculastrum* when the seven data sets are analyzed in combination using maximum parsimony. The trichotomy at the base of the tree is consistent with the resolution of relationships among the major clades of *Primula* in Mast et al. (2001). Tree statistics are given above the strict consensus tree. Bootstrap frequencies (as a percentage) are given above the branches. A unique change in an indel character is shown with a black box, and a non-unique change (an event that occurs multiple times or a reversal) is shown with a hollow box. Coding of indels is found in Table 2. Vertical designations of taxa to the right of the tree are (from left to right) species complexes (the abbreviated *Dodecatheon hendersonii* and *D. frigidum* complexes), sections (including the abbreviated *Dodecatheon* section *Capitulum* and *Primula* sections *Suffrutescens* and *Amethystina*), and genus *Dodecatheon* and *Primula* subgenus *Auriculastrum*.

TABLE 3. Hypothesis testing. One randomly chosen shortest tree from each of the constrained maximum parsimony (MP) searches was compared to one randomly chosen tree from the respective unconstrained MP search. The MP searches and the winning sites (WS) tests involved parsimony informative nucleotides (nts) and insertion and/or deletion events (indels), but all nts (and only nts) of the respective data sets were considered in the Shimodaira-Hasegawa (SH) test. The SYM substitution model (Zharkikh, 1994), as chosen by MrModeltest 1.1b, was used for the SH test. For the WS test, all characters that differed between the two topologies differed by one step. Hence the number of characters supporting the unconstrained tree (No.<sub>UNCON</sub>) minus the number of characters supporting the constrained tree (No.<sub>CON</sub>) equals the length difference ( $\Delta$ ) between the constrained and unconstrained trees. *P* values  $\leq 0.05$  appear in boldface type.

Data set/Constraint	SH test		Length/ $\Delta$	WS test		
	-ln L/ $\Delta$	<i>P</i>		No. <sub>UNCON</sub>	No. <sub>CON</sub>	<i>P</i>
<i>matK</i> (expanded 75-taxa data set)						
Unconstrained	7621.76275		665			
<i>Dodecatheon</i> sister to <i>Primula</i>	+149.51486	<b>0.000</b>	+30	32	2	< <b>0.0001</b>
<i>Primula</i> sect. <i>Amethystina</i> sister to clade of <i>Dodecatheon</i> and <i>Primula</i> subgenus <i>Auriculastrum</i>	+131.55301	<b>0.000</b>	+31	34	3	< <b>0.0001</b>
<i>Primula</i> sect. <i>Parryi</i> sister to <i>Dodecatheon</i>	+17.53018	0.054	+2	2	0	0.5000
<i>Dodecatheon</i> sect. <i>Purpureo-tubulosa</i> monophyletic	+58.35976	<b>0.002</b>	+10	11	1	<b>0.0063</b>
Combined cpDNA (70-taxa data set)						
Unconstrained			1498			
<i>Primula</i> sect. <i>Amethystina</i> sister to clade of <i>Dodecatheon</i> and <i>Primula</i> subgenus <i>Auriculastrum</i>			+89	95	6	< <b>0.0001</b>
<i>Primula</i> sect. <i>Parryi</i> sister to <i>Dodecatheon</i>			+7	9	2	0.0654
<i>Dodecatheon</i> sect. <i>Purpureo-tubulosa</i> monophyletic			+27	28	1	< <b>0.0001</b>

*lum*. The trichotomy is not resolved in any of the 76 shortest MP trees for the combined data.

In contrast, the two species of the paraphyletic *Dodecatheon frigidum* complex are resolved as the earliest diverging species in the two major clades of *Dodecatheon*. They both lack a filament tube, but this is the ancestral character state for *Dodecatheon* (it is absent in the closely related species of *Primula*) and thus is not a synapomorphy. These two species are also disjunct in their distributions, with *D. conjugens* occurring in the mountains of the northwestern US and adjacent Canada (Thompson, 1953; Cholewa and Henderson, 1993) and *D. frigidum* occurring in Alaska, adjacent Canada, and across the Bering Strait in Siberia (Thompson, 1953; Hultén, 1968). Thompson's (1953, p. 101) observation that the two species are both "continental. . . in the sense that they avoid the maritime areas of the Pacific Coast adjacent to their ranges" in support of grouping them together ignores the maritime range of *D. frigidum* along the Bering Sea and Arctic Ocean. Thus, like the absence of a filament tube, we do not consider their geographic distributions to conflict with anther rugosity and the cpDNA phylogeny.

The monophyly of section *Capitulum* (three spp.) is strongly supported (100% posterior probability, Fig. 1; 98% bootstrap frequency, Fig. 3) in the cpDNA phylogeny. Its monophyly is further corroborated by its unique possession (within *Dodecatheon*) of the following derived character states: (1) enlarged stigmatic papillae, (2) angular seeds with thin membranes along the edges, and (3) first true leaves arising from the base of the cotyledons (Thompson, 1953).

However, within section *Capitulum*, a reconsideration of species circumscriptions appears warranted (Figs. 1 and 3). Differentiation of the species in the section (*D. jeffreyi*, *D. redolens*, and *D. alpinum*) hinges upon flower merosity (four- and five-merous, solely four-merous, or solely five-merous, respectively), capsule dehiscence (usually with an irregular operculum and occasionally valvate in *D. jeffreyi* or solely valvate in the other two), pubescence (glandular-pubescent to glabrous, solely glandular-pubescent, or solely glabrous, respectively), and features of the corolla tube (completely yellow

tube covering the anther bases in *D. redolens* or tube maroon at base and not covering anther bases in the other two; Thompson, 1953). *Dodecatheon jeffreyi* is the most widespread of the three species, intergrades with the other two where they are sympatric (Thompson, 1953; Cholewa and Henderson, 1993; but see Hall, 1912 and Clausen et al., 1940), and encompasses the morphological variation in the other two (with the exception of the corolla tube character mentioned).

Given this, it seems reasonable to expect that the other two taxa are derived from *D. jeffreyi* once (*D. redolens*, if the point of corolla tube reflexion and tube coloration are viewed as synapomorphies) or perhaps many times (*D. alpinum*, if it is a high elevation ecotype of *D. jeffreyi*). Both *D. redolens* and *D. alpinum* have been previously recognized as varieties of *D. jeffreyi* (by Hall, 1901 and Gray, 1886, respectively), though not recently. The accessions of *D. jeffreyi* and *D. alpinum* that are placed together in the phylogeny were collected from locations geographically closer to each other than the second accession assignable to the same species. *Dodecatheon jeffreyi* subsp. *jeffreyi* (Feller & Mast 580) and *D. alpinum* subsp. *majus* (Feller & Mast 592) were both collected in northern California (Siskiyou and Plumas counties, respectively); *D. jeffreyi* subsp. *jeffreyi* (Feller & Mast 630) and *D. alpinum* subsp. *majus* (Feller & Mast 631) were both collected in central California (Yosemite National Park).

The monophyly of section *Dodecatheon* (five spp.) is strongly supported (100% posterior probability, Fig. 1; 100% bootstrap frequency, Fig. 3) in the cpDNA phylogeny (Fig. 3), and the undescribed species from the Pacific Northwest can be considered as a member. Its monophyly is further corroborated by its unique seedling development (within *Dodecatheon*), in which the origin of the first true leaves is above ground from the hypocotyl (Thompson, 1953).

However, as in section *Capitulum*, species circumscriptions within section *Dodecatheon* (Figs. 1 and 3) merit a reexamination. *Dodecatheon dentatum* appears to be a paraphyletic species with respect to other members of section *Dodecatheon* and the undescribed species. Features cited by Thompson (1953, p. 121) to uniquely distinguish *D. dentatum* from other

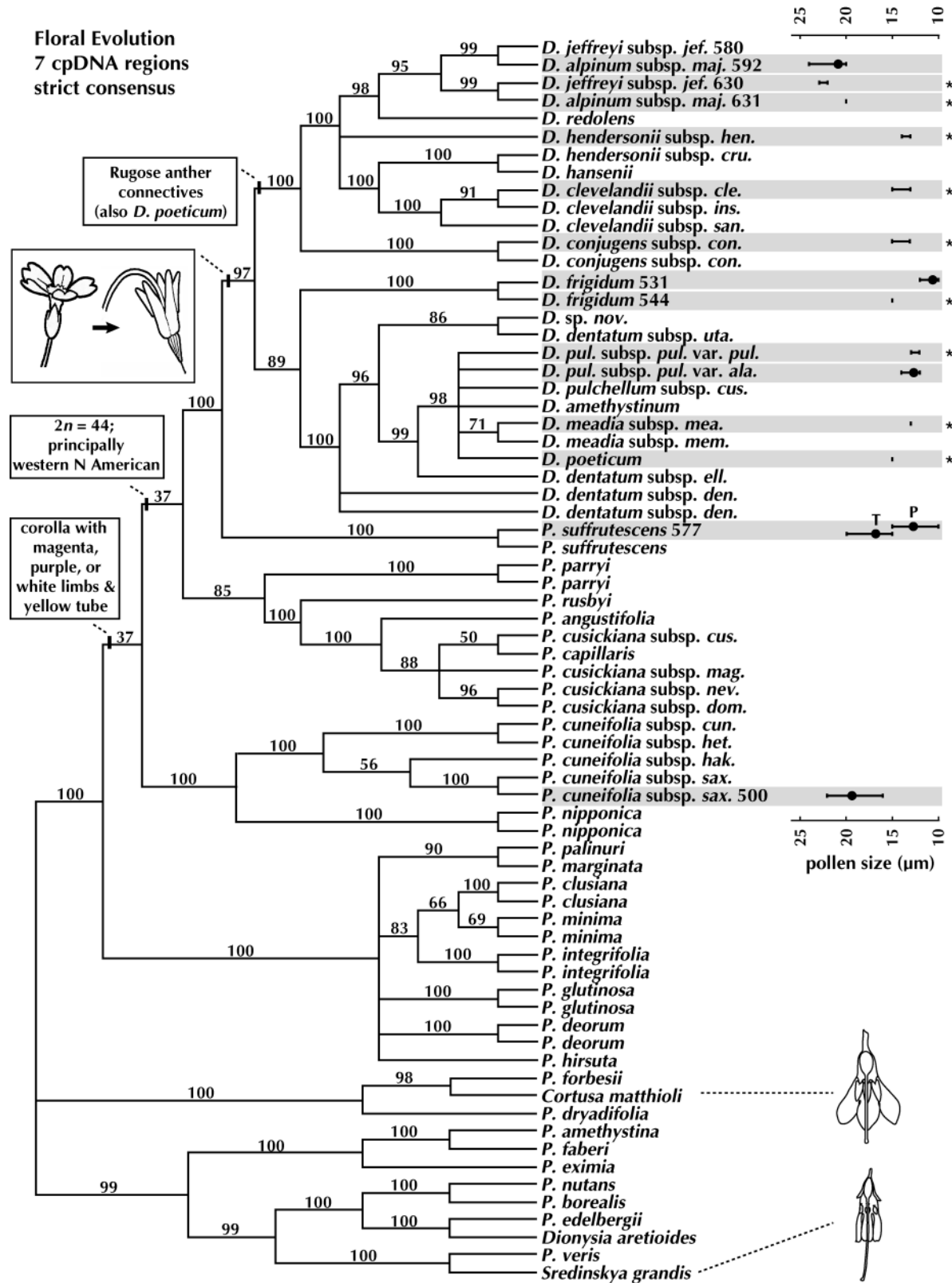

Fig. 4. Tree topology and bootstrap frequencies of Fig. 3 with floral, cytological, and biogeographic patterns observed in *Dodecatheon* and *Primula* subgenus *Auriculastrum*. Pollen size measurements are shown to the right of the tree. Dots indicate the mean size, and bars show the range of measured sizes. Measurements marked with an asterisk were made by Wendelbo (1961b), who reported the range of observed sizes but not the mean size. T, thrum; P, pin.

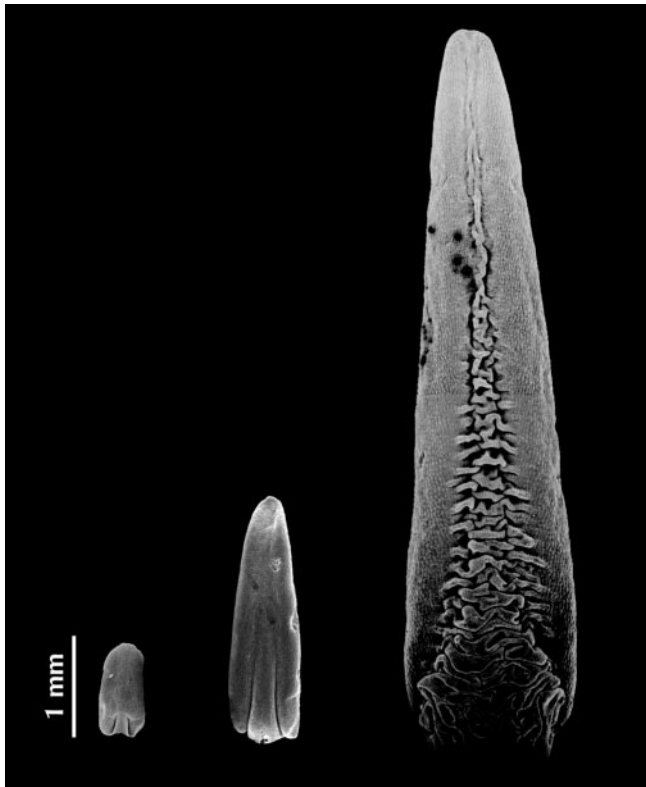

Fig. 5. Scanning electron micrographs of the anthers of (from left to right) *Primula suffrutescens*, *Dodecatheon pulchellum*, and *D. jeffreyi*. The species with smooth anther connectives do not have characteristically smaller anthers than those with rugose anther connectives. The size variation between the two is meant to reflect the size variation seen in *Dodecatheon*.

species in the genus include its consistently white corolla limbs and its subulate anthers. *Dodecatheon dentatum* subsp. *utahense* has pink or violet limbs (Holmgren, 1994; he recognized it as a variety carved out of *D. dentatum* var. *ellisiae*), and Thompson (1953, p. 151) reports both subulate and lanceolate anthers in *D. dentatum* subsp. *ellisiae* (the latter type is the anther type seen in the remaining members of section *Dodecatheon*). Thus, the combination of white corolla limbs and subulate anthers would only consistently distinguish *D. dentatum* subsp. *dentatum* and some specimens of *D. dentatum* subsp. *ellisiae* from other taxa of *Dodecatheon*. *Dodecatheon dentatum* subsp. *dentatum*, *utahense*, and *ellisiae* are geographically disjunct (by more than 500 km between any two of them) in the Pacific Northwest, Utah, and Arizona and New Mexico, respectively. The genetic distance between the subspecies of *D. dentatum* (up to 0.7% using the Hasegawa et al. [1985] model of sequence evolution for the combined seven-region data set) is in striking contrast to that seen between the four remaining species in section *Dodecatheon* (up to 0.1%). It is somewhat surprising that the undescribed species from the North Coast Range (and possibly also the Siskiyou Mountains; Chambers, 1999) is resolved as most closely related to subsp. *utahense*, rather than the geographically closer subsp. *dentatum* from the Pacific Northwest. However, like subsp. *utahense*, and unlike subsp. *dentatum*, the undescribed species has a non-white (red-purple; Chambers, 1999) corolla. If population-level sampling corroborates the genetic distinctiveness of the subspecies of *D. dentatum*, and the paraphyly of *D.*

*dentatum* relative to the rest of section *Dodecatheon*, then the subspecies are best elevated to specific rank.

Among the remaining species of section *Dodecatheon* is *D. poeticum*, a species with both smooth and rugose anther connectives in a clade with smooth connectives (Fig. 4). A possible interpretation for the presence of rugose connectives in *D. poeticum* would involve two independent origins of the rugose phenotype in *D. poeticum* and in the MRCA of the large clade with rugose connectives. However, *D. poeticum* ( $2n = 88$ ; Thompson, 1953) is likely an allopolyploid with *D. hendersonii* subsp. *hendersonii* ( $2n = 44$ ; from the clade with rugose connectives) and *D. pulchellum* subsp. *cusickii* ( $2n = 44, 88$ ; Suttill and Allen, 1992; from the clade with smooth connectives) as parents (Thompson, 1953).

*Dodecatheon hendersonii* subsp. *hendersonii* is common west of the Cascade Mountains and extends up the Columbia River Gorge. *Dodecatheon pulchellum* subsp. *cusickii* is common to the east of the Cascade Mountains and extends down the Columbia River Gorge. *Dodecatheon poeticum* occurs where these two taxa meet, and the phenotype of *D. poeticum* appears to be a chimera of the two parents (Thompson, 1953). Given the position of *D. poeticum* in the combined cpDNA phylogeny, *D. pulchellum* subsp. *cusickii* was likely the maternal parent (for at least the allopolyploid event sampled here; there might have been more than one to produce the heterogeneous *D. poeticum*). Thus, the genetics underlying the rugose phenotype is likely of common origin in all species with rugose connectives in *Dodecatheon*, with a transfer of it to *D. poeticum* during the polyploidization event(s). Suttill and Allen's (1992) report of an accession of *D. poeticum* with  $2n = 44$  is contrary to this and merits further examination.

A phylogeny reconstructed using a bi-parentally or paternally inherited molecular marker will provide a further test of this hypothesis for *D. poeticum* and could provide insights into the degree to which extant taxa of *Dodecatheon* are reproductively isolated and the extent to which hybridization and introgression and allopolyploidization have played roles in their evolutionary history. This additional data will be critical to making informed taxonomic realignments in the group.

**Phylogenetic relationships in *Primula* subgenus *Auriculastrum***—The sister relationship between *Dodecatheon* and *Primula* section *Suffrutescens*, first observed by Mast et al. (2001) and strongly supported here with increased taxon and character sampling (100% posterior probability, Fig. 1; 100% bootstrap frequency, Fig. 3), is unexpected given the greater morphological and ecological similarities between members of *Dodecatheon* and *Primula* section *Parryi*. The special attention drawn to the similarities between *Dodecatheon jeffreyi* and *Primula parryi* by Thompson (1953, p. 75) is warranted. Each grows in moist mountain meadows and streamsides and has long (up to ca. 50 cm) scapes that arise from a rosette of fleshy, oblanceolate leaves and support an umbel of ca. 5–20 flowers with pedicels of similar length (ca. 3–5 cm) at flowering (Thompson, 1953; S. Kelso, unpublished manuscript). These features differ from the smaller *P. suffrutescens*, a mat-forming species of rocky alpine slopes, having shorter, fleshy, cuneate leaves and fewer flowers on shorter pedicels and scapes (Kelso, 1991). Chromosome numbers ( $2n = 44$ ), also cited as similar between *D. jeffreyi* and *P. parryi*, are, however, shared between *Dodecatheon* and both *Primula* sections *Parryi* and *Suffrutescens* (Fig. 4). One might conclude that the morphological features shared by *D. jeffreyi* and *P. parryi* are

the ancestral states for their MRCA and that *P. suffrutescens* simply represents divergence from it in its rocky, high alpine habitat. However, morphologies similar to *P. suffrutescens* occur in sections *Cuneifolia* (both species) and *Auricula* (e.g., *P. hirsuta* and *P. minima*) and thereby complicate the reconstruction of ancestral states in the group.

The clade formed by *Dodecatheon* and *Primula* sections *Suffrutescens* and *Parryi* (21 spp. in total) is poorly supported in the cpDNA phylogeny (37% bootstrap frequency, Fig. 3). However, members of the clade have similar distributions and chromosome numbers. This is the largest clade (21 spp.) in the Primulaceae (sensu Källersjö et al., 2000) for which all members can be found in North America (principally western North America; Fig. 4). Furthermore, *Primula* sections *Suffrutescens* and *Parryi* and the earliest diverged species of *Dodecatheon* have chromosome numbers of  $2n = 44$  (Fig. 4), as opposed to  $2n = 66$  in the European section *Auricula* (Richards, 2002) or  $2n = 22$  in the Pacific coastal *Cuneifolia* (Kelso, 1991).

Ours is the first published phylogenetic study to sample more than two taxa of the western North American *Primula* section *Parryi*, and we sampled all eight taxa recognized as members of the section by Holmgren and Kelso (2001). The section offers a model for understanding the effects of Pleistocene climatic and vegetation changes on the flora of the Intermountain Region of western North America (Holmgren and Kelso, 2001), but much of the elucidation of this will come with finer-scale population sampling of the taxa. At present, we will let it suffice to note the strong support for the section's monophyly (85% bootstrap frequency, Fig. 3), the basal split between *P. parryi* (the most widespread taxon of the section and that species most similar to *Dodecatheon*) and the remaining taxa, and the possible, though poorly supported (50% bootstrap frequency, Fig. 3) paraphyly of *P. cusickiana* with respect to *P. capillaris*.

The monophyly of the two remaining sections, *Cuneifolia* (as recognized to exclude *P. suffrutescens*; Richards, 2002) and *Auricula*, is strongly supported (100% and 85% posterior probability, respectively, Fig. 1; both at 100% bootstrap frequency, Fig. 3), and all relationships among their sampled members in the seven-region strict consensus (Fig. 3) are consistent with previous studies by Fujii et al. (1995, 1999; *Cuneifolia*) and Zhang (2002; *Auricula*). These authors provide abundant observations regarding the implications of the inferred relationships.

Conspicuously absent in the clade of *Dodecatheon* and *Primula* subgenus *Auriculastrum* are the sampled members of *Primula* section *Amethystina* (Fig. 3). Mast et al. (2001) drew special attention to this small section, which can be found in moist, peaty meadows in Asia, because (1) it remained unsampled in that study, (2) its thick, toothed leaves and globose capsules are reminiscent of subgenus *Auriculastrum* (Smith and Fletcher, 1942), (3) uncertainty remains regarding the leaf vernation type in the section (Smith and Fletcher, 1942, 1950; Wendelbo, 1961a; sketches by J. Haldova in Halda, 1992), and (4) its distribution in the Himalayan Mountains and neighboring regions would bridge the gap between the currently recognized distribution of *Primula* subgenus *Auriculastrum* and the region of greatest diversity in *Primula*. The species of section *Amethystina* uniquely (in *Primula*) share pitted glands in their leaves (Smith and Fletcher, 1942), a synapomorphy that supports the section's monophyly.

Our analysis places the two sampled members of this sec-

tion with *P. eximia* among the outgroup taxa with strong support (100% posterior probability, Fig. 1; 100% bootstrap frequency, Fig. 3), and a sister relationship between this section and the clade composed of *Dodecatheon* and *Primula* subgenus *Auriculastrum* is significantly rejected by the data (Table 3). Thus, the descendants of the MRCA of subgenus *Auriculastrum* remain extra-Himalayan in their distribution, and the similarities of subgenus *Auriculastrum* and section *Amethystina* appear to be independently derived. The persistent confusion surrounding the leaf vernation type of this section (a character otherwise thought to have undergone few evolutionary shifts in the Primulaceae; Mast et al., 2001) merits a comparative developmental study.

***Dodecatheon* represents a breakdown in heterostyly**—The likely shift from distylous flowers that offered nectar as a reward in the MRCA of *Primula suffrutescens* and *Dodecatheon* to monomorphic, solanoid flowers that offered pollen as a reward in the MRCA of *Dodecatheon* raises at least two interesting questions: (1) Which alleles were fixed in the heterostyly linkage group of *Dodecatheon*, if it persists in that genus? and (2) What further morphological changes were necessary to get from one floral type to the other?

The evolutionary steps traditionally posed for the shift from self/intra-morph incompatible heterostyly to self/intra-morph compatible monomorphy in *Primula* involve a recombination in the linkage group between the locus responsible for style length and female mating type (G) and the loci responsible for pollen size and male mating type (P; we will discuss this as a single locus for simplicity) and anther height (A) (Ernst, 1955; Dowrick, 1956; Charlesworth and Charlesworth, 1979; Wedderburn and Richards, 1992; Al Wadi and Richards, 1993; Richards, 1993, 1997). This is followed by the fixation in the population of the recombinant with the long style length of the pin and the recessive female mating type (g) and the high anther height, dominant male mating type, and larger pollen size of the thrum (PA). This allows the pollen of any flower to pollinate any ovule in the population, and it positions the anther and stigma at the same height in the flower (the long “homostyle;” Darwin, 1877; Path A in Fig. 6). These events are thought to have occurred in most of the 17 sections of *Primula* in which long homostyles are found (Wedderburn and Richards, 1992; Richards, 1993, 1997). However, there is evidence derived from their incompatibility reactions that some of these might represent monomorphic lineages diverged from the MRCA of *Primula* prior to the origin of heterostyly in the group (Ernst, 1955; Wedderburn and Richards, 1992; Al Wadi and Richards, 1993; Richards, 1993, 1997, 2002; but see Baker, 1966). Our observation that the pollen of *P. cuneifolia* subsp. *saxifragifolia* is the same size as, or slightly larger than, the thrum pollen of *P. suffrutescens* is consistent with a recombinatory origin of long homostyly in *P. cuneifolia* subsp. *saxifragifolia*. Charlesworth and Charlesworth (1979) have shown mathematically why other single recombinants (Gpa, GpA, and gpA) in the heterostyly linkage group would be at a selective disadvantage relative to the nonrecombined dominant and recessive alleles or the “long homostyle” alleles. Only once has the “short homostyle” phenotype (presumably the Gpa alleles) been fixed in a taxon of *Primula* (*P. septemloba* var. *minor*; Richards, 2002).

Though long or short homostyly by genetic recombination has previously appeared to be the only route to persistent monomorphy in natural populations of *Primula*, the available phe-

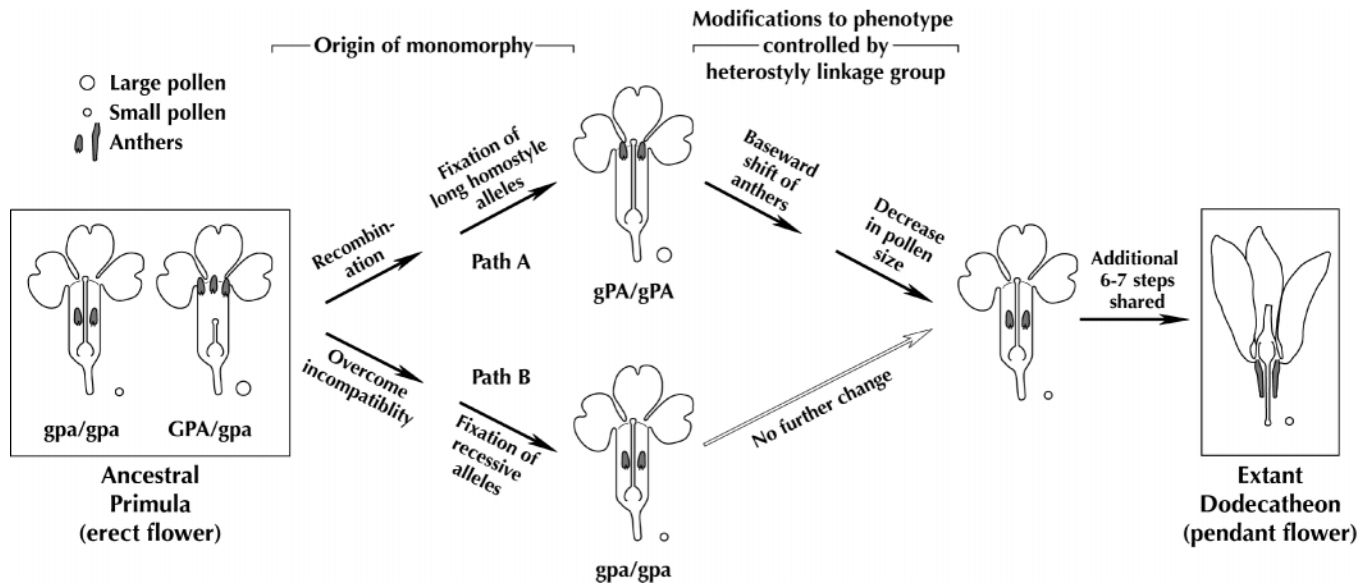

Fig. 6. Alternative pathways from the ancestral heterostylous flower of *Primula* to the extant monomorphic flower of *Dodecatheon*. Path A involves recombination in the heterostylous linkage group and morphological changes in the phenotype controlled by it. Path B involves the breakdown of self/intra-morph incompatibility and the fixation of the recessive alleles without further changes to the phenotype controlled by it. The exact ordering of arrows along the paths is not meant to indicate the necessary order of events, but rather all events along a path appear to have necessarily occurred in some order to get from the ancestral flower of *Primula* to the extant flower of *Dodecatheon*. See the Introduction for further information on the genotypes given below the cartoon flowers at the left of the figure.

notypic observations of *Dodecatheon* suggest something new: monomorphy through the fixation of the recessive alleles (path B in Fig. 6). As in the pin of *Primula*, the anthers of *Dodecatheon* arise from the lower portion of the corolla (relative to its total length), and the long style is well exerted beyond the tips of the anthers (approach herkogamy). Furthermore, the length of the subspherical pollen in all examined species of *Dodecatheon*, except those in section *Capitulum*, is 10–15  $\mu\text{m}$  in size (Fig. 4; Wendelbo, 1961b). This is the range of sizes that we observed for the pin pollen of *P. suffrutescens* (Fig. 4) and smaller than that species' thrum pollen. *Dodecatheon alpinum* and *D. jeffreyi* of section *Capitulum* have ellipsoidal pollen that is 20–24  $\mu\text{m}$  along the long axis, suggesting an increase in pollen size from the smaller size that we infer to be primitive for the genus. This is unexpected, given that small pollen size is commonly described as an adaptation to buzz pollination (e.g., Buchman, 1983), but it suggests that pollen sizes within the range observed in *Dodecatheon* (10–24  $\mu\text{m}$ ) might be equally suited to the syndrome. Apparently concurrent with this increase in pollen size was an increase in length of the stigmatic papillae, for section *Capitulum* is unique in *Dodecatheon* in its possession of an enlarged stigma (Thompson, 1953).

The origin of monomorphy in *Dodecatheon* from a heterostylous ancestor requires a shift from self/intra-morph incompatibility to intra-morph compatibility either by overcoming the incompatibility by recombination (path A of Fig. 6) or by at least a partial breakdown in it (path B in Fig. 6). Partial breakdowns of self/intra-morph incompatibility are common in *Primula*, where 77% of 35 examined species set seed after the self-pollination of pins (Wedderburn and Richards, 1990). In the extreme case, 61.8% of pin ovules pollinated with self-pollen in *P. vulgaris* (of *Primula* subgenus *Primula*) set viable seed, compared to 70.1% of pin ovules pollinated by thrum pollen (Wedderburn and Richards, 1990). This incompleteness

in the self/intra-morph incompatibility system has permitted a number of true-breeding pin lines (homozygous recessive individuals) in cultivation (Richards, 1993).

The fixation of the recessive alleles could have arisen by stochastic events (founder events or genetic drift in small populations) or by selection. The MRCA of *Dodecatheon* likely arose in western North America, where *Primula* sections *Suffrutescens* and *Parryi* and the earliest diverged species of *Dodecatheon* are found. The extensive climatic, orogenic, and biological changes in this region during the Tertiary and Quaternary are well documented (Graham, 1999), and we can reasonably assume then-extant populations to have gone through numerous founding events, population size fluctuations, and periods of isolation during that time. Founder events and genetic drift have been hypothesized to play a role in the generation of populations lacking one or two (in the case of tristyly) floral morphs in other heterostylous species (e.g., Barrett et al., 1989; Husband and Barrett, 1992; Eckert and Barrett, 1992, 1995; Mal and Lovett-Doust, 1997; Thompson et al., 1998; Endels et al., 2002). The inbreeding depression expected with the genetic bottleneck in this scenario might have been partially ameliorated by the polyploidy of these individuals ( $2n = 44$  is shared by *Primula* sections *Suffrutescens* and *Parryi* and the earliest diverged species of *Dodecatheon*, Fig. 4; polyploidy and inbreeding depression reviewed in Soltis and Soltis, 2000). Alternatively, changes during the Tertiary and Quaternary might have led to positive selection for the pin or negative selection for the thrum, perhaps due to changes in the available pollinators (Barrett et al., 1989; Washitani, 1996; Dos Santos, 2002) or rates of pollen or anther herbivory (Olesen, 1979; Leege and Wolfe, 2002).

At least six additional phenotypic modifications are required to produce the solanoid flower type shared by all species of *Dodecatheon*, in addition to those that produce monomorphic approach herkogamy (Fig. 6). They include shifts from (1)

reflexion of the petals near the stigma to reflexion near the anthers, (2) simultaneous longitudinal dehiscence of the anther sacs to delayed longitudinal dehiscence along much of its length (to produce “poricidal” anthers in the first day[s] of anthesis; Harder and Barclay, 1994), (3) small to large anthers (Fig. 4; with perhaps a 10-fold increase in number of pollen grains per anther, as suggested by comparing counts from Harder and Barclay, 1994, and Piper and Charlesworth, 1986), (4) reflexion of the petals from 90° to 180°, (5) erect or horizontal (there is variation in flower orientation in the umbels of close relatives) to more pendant flowers at anthesis, and (6) broad, notched petal limbs to narrow, unnotched limbs.

An additional shift that might have occurred at this time is the cessation of nectar production (Macior, 1970; Harder and Barclay, 1994; assumption of nectar by Macior, 1964, since disproved, L. W. Macior, University of Akron, personal communication), though this merits a more systematic morphological and histological examination than has been performed to date. *Primula* has mesophyll nectaries, with the nectar secreted through modified stomata on the ovary (Vogel, 1986); an SEM study of *Dodecatheon jeffreyi*, *D. frigidum*, and *D. pulchellum* suggests that these stomata persist in *Dodecatheon* (D. M. S. Feller, unpublished data). The histology of the mesophyll in the ovary of *Dodecatheon* has yet to be examined.

While the actual ordering of these six (or seven) events will never be known with certainty (and some might have occurred prior to the fixation of a single floral morphology), some of them are more likely to have occurred prior to others. For example, a shift to reflexion of the petals near the anthers would have likely been necessary prior to an increase in anther size, given that the anthers could not have increased much in volume within the confines of the corolla tube. Such a shift is observed in the *split perianth* mutant of polyanthus hybrids of *Primula* (*P. × tommasinii*; *Primula* subgenus *Primula*), where it is dominant to the wild type (Webster and Gilmartin, 2003). Coinciding with this greater availability of the anthers, and prior to their increase in size and pollen number, was likely the evolution of delayed longitudinal dehiscence. Delayed dehiscence provides a dispensing mechanism with which the plants can restrict pollen removal by individual visitors following a dispensing schedule that increases total dispersal of pollen (Harder and Thomson, 1989; Harder and Barclay, 1994; Harder and Wilson, 1994).

Persistent monomorphy by fixation of the recessive alleles is previously undescribed for species of *Primula*, yet two additional instances of it might exist. Both of these are provided by previously distinct genera with approach herkogamy that are now thought to be descended from the MRCA of *Primula*: the genera *Sredinskya* and *Cortusa* (Figs. 1 and 3; Wendelbo, 1961b; Richards, 1993, 2002; Mast et al., 2001; Trift et al., 2002). *Sredinskya* is a monotypic genus from the Caucasus that differs from its closest relatives in *Primula* subgenus *Primula* in its monomorphic, pendent flowers with unbent petals (Fig. 4). *Cortusa* consists of one to a few species that are widespread in Eurasia, and it differs from its closest relatives in *Primula* subgenus *Auganthus* in its monomorphic, pendent, bell-shaped flowers that have fused filaments and connivent anthers (as in most species of *Dodecatheon*; Fig. 4). Like *Dodecatheon*, it is thought to offer exclusively pollen as a pollinator reward (Vogel, 1986).

The hypothesis of the fixation of recessive alleles in *Dodecatheon*, and perhaps also in *Sredinskya* and *Cortusa*, will be most decisively tested following a molecular genetic char-

acterization of the heterostyly linkage group in *Primula* and these taxa. A less decisive test of the hypothesis can perhaps be made by examining the patterns of crossing success between these taxa and the two morphs of close heterostylous relatives. Evidence derived from such an approach led Barrett and Shore (1987) to conclude that the approach herkogamy in monomorphic species of *Turnera ulmifolia* var. *angustifolia* involved genetic recombination of the heterostyly linkage group to produce a long homostyle with subsequent morphological change, rather than a divergence of the taxon prior to the evolution of heterostyly in that group (Barrett, 1978). While differential success provides evidence for recombination, the lack of it could be explained in several ways: by the absence of recombination, by the breakdown in self/intra-morph incompatibilities that no longer have any selective advantage (Baker, 1966), or by the buildup of unrelated physiological incompatibilities during or following the divergence of these taxa from their closest relatives in *Primula*. We are unaware of any attempts to perform such crossing experiments involving *Dodecatheon*, *Sredinskya*, or *Cortusa*.

#### *Evolution of flower color and anther connective texture*—

Two additional floral features merit consideration because they are associated with the buzz pollination of *Dodecatheon*, yet changes in them did not occur with the origin of the MRCA of that genus. The origin of the first, a purple or magenta flower with a yellow eye, is likely to have occurred well prior to the MRCA of *Dodecatheon*. Whereas the origin of the second, the rugose connectives of half of the species of *Dodecatheon*, is likely to have arisen once with the MRCA of one of the clades formed at that group’s basal split.

The flowers of *Dodecatheon* have a short corolla tube that is yellow near the apex, corolla limbs that are often white near the base and magenta, purple, or (rarely) white along the rest of their length, and an androecium that often includes a mix of yellow and darker colors (red, maroon, or black; Thompson, 1953). This strong contrast between the yellow color in the neighborhood of the androecium and the typically purple corolla limbs is thought to direct the pollinators to the anthers in solanoid, buzz-pollinated flowers (Buchman, 1983; Faegri, 1986). Macior’s (1964) manipulation experiments, in which flowers of *D. meadia* were not visited when the yellow portion of the corolla tube and the corolla limbs were removed, support its importance (in its coloration or, alternatively, in its shape, scent, or provision of a landing structure) for pollinator attraction. However, *Primula* sections *Suffrutescens*, *Parryi*, and *Cuneifolia* (and many other species of *Primula*) also have magenta, purple, or (rarely) white corolla limbs, a yellow corolla tube, and a yellow androecium. The coloration in these species likely directs the pollinators to the mouth of the corolla tube and to the nectar produced at the base of the gynoecium (Barth, 1991). Thus, the preexisting color pattern in the MRCA of *Dodecatheon* and *Primula* section *Suffrutescens* might have facilitated the shift to buzz pollination. This hypothesized co-opting of the coloration’s old function (as a nectar guide) for the new one (to increase the apparency of the anthers) would make it a “transfer exaptation” (Gould and Vrba, 1982; Arnold, 1994; Armbruster, 1997) in *Dodecatheon*.

As noted, the rugose anther connectives of half of the species of *Dodecatheon* likely arose with the MRCA of one of the two clades formed at the basal split in *Dodecatheon* (Fig. 4). Given the importance of the androecium as a foothold for the vibrating pollinators (Macior, 1964, 1970; Harder and Bar-

clay, 1994), it seems reasonable to hypothesize that the transverse ridges on the anther connectives (and often the filaments as well; Fig. 5) provide a more certain footing for the pollinator. Bees visiting species with smooth anther connectives, such as the two (*D. amethystinum* and *D. meadia*) studied by Macior (1964, 1970), appear to transfer pollen successfully without this innovation. However, Roberts (1969) observed that bees visiting flowers of *Cassia* and *Solanum* were frequently dislodged by their own vibrations, and thus features of the flower in contact with the vibrating pollinators likely play a role in the frequency of successful pollination. If indeed the rugosity serves a function relevant to the fitness of the plant and it arose for this current function, as suggested here, it is an adaptation (sensu Gould and Vrba, 1982) in *Dodecatheon*. We are unaware of any previous hypotheses regarding the adaptive significance of the rugose anther connectives in *Dodecatheon*.

#### LITERATURE CITED

- AL WADI, H., AND A. J. RICHARDS. 1993. Primary homostyly in *Primula* L. subgenus *Sphondylia* (Duby) Rupr. and the evolution of distyly in *Primula*. *New Phytologist* 124: 329–338.
- ARMBRUSTER, W. S. 1997. Exaptations link evolution of plant–herbivore and plant–pollinator interactions: a phylogenetic inquiry. *Ecology* 78: 1661–1672.
- ARNOLD, E. N. 1994. Investigating the origins of performance advantage: adaptation, exaptation and lineage effects. In P. Eggleton and R. I. Vane-Wright [eds.], *Phylogenetics and ecology*, 123–168. Academic Press, London, UK.
- BAKER, H. G. 1966. The evolution, functioning and breakdown of heteromorphic incompatibility systems. I. The Plumbaginaceae. *Evolution* 20: 349–368.
- BARRETT, S. C. H. 1978. Heterostyly in a tropical weed: The reproductive biology of the *Turnera ulmifolia* complex (Turneraceae). *Canadian Journal of Botany* 56: 1713–1725.
- BARRETT, S. C. H. 2002. The evolution of plant sexual diversity. *Nature* 3: 274–284.
- BARRETT, S. C. H., AND M. B. CRUZAN. 1994. Incompatibility in heterostylous plants. In E. G. Williams, A. E. Clarke, and R. B. Knox [eds.], *Genetic control of self-incompatibility and reproductive development in flowering plants*, 189–219. Kluwer Academic Publishers, Dordrecht, The Netherlands.
- BARRETT, S. C. H., L. K. JESSON, AND A. M. BAKER. 2000. The evolution and function of stylar polymorphisms in flowering plants. *Annals of Botany* 85: 253–265.
- BARRETT, S. C. H., M. T. MORGAN, AND B. C. HUSBAND. 1989. The dissolution of a complex genetic polymorphism: the evolution of self-fertilization in tristylous *Eichhornia paniculata* (Pontederiaceae). *Evolution* 43: 1398–1416.
- BARRETT, S. C. H., AND J. S. SHORE. 1987. Variation and evolution of breeding systems in the *Turnera ulmifolia* L. complex (Turneraceae). *Evolution* 41: 340–354.
- BARTH, F. G. 1991. *Insects and flowers: the biology of a partnership*. Princeton University Press, Princeton, New Jersey, USA.
- BATESON, W., AND R. P. GREGORY. 1905. On the inheritance of heterostyly in *Primula*. *Proceedings of the Royal Academy of London, Series B* 76: 581–586.
- BAUM, D. A., W. S. ALVERSON, AND R. NYFFELER. 1998a. A durian by any other name: taxonomy and nomenclature of the core Malvales. *Harvard Papers in Botany* 3: 315–330.
- BAUM, D. A., R. L. SMALL, AND J. F. WENDEL. 1998b. Biogeography and floral evolution of baobabs (*Adansonia*, Bombacaceae) as inferred from multiple data sets. *Systematic Biology* 47: 181–207.
- BIRKY, C. W. J. 1995. Uniparental inheritance of mitochondrial and chloroplast genes: mechanisms and evolution. *Proceedings of the National Academy of Sciences, USA* 92: 11331–11338.
- BUCHMANN, S. L. 1983. Buzz pollination in angiosperms. In C. E. Jones and R. J. Little [eds.], *Handbook of experimental pollination biology*, 73–113. Van Nostrand Reinhold, New York, New York, USA.
- CHAMBERS, K. L. 1999. In shooting stars, little things mean a lot. *Oregon Flora Newsletter* 5: 1, 4.
- CHARLESWORTH, B., AND D. CHARLESWORTH. 1979. The maintenance and breakdown of distyly. *American Naturalist* 114: 499–513.
- CHOLEWA, A. F., AND D. M. HENDERSON. 1993. Primulaceae. In J. C. Hickman [ed.], *The Jepson manual: higher plants of California*, 905–911. University of California Press, Berkeley, California, USA.
- CLAUSEN, J., D. D. KECK, AND W. M. HIESEY. 1940. Experimental studies on the nature of species: I. Effect of varied environments on western North American plants. Publication No. 520. Carnegie Institution of Washington, Washington, DC, USA.
- CORRIVEAU, J. L., AND A. W. COLEMAN. 1988. Rapid screening method to detect potential biparental inheritance of plastid DNA and results for over 200 angiosperm species. *American Journal of Botany* 75: 1443–1458.
- DARWIN, C. 1862. On the two forms, or dimorphic condition, in species of *Primula*, and on their remarkable sexual relations. *Proceedings of the Linnean Society Botany* 6: 77–96.
- DARWIN, C. 1877. *The different forms of flowers on plants of the same species*. Murray, London, UK.
- DOS SANTOS, I. A. 2002. Flower-visiting bees and the breakdown of the tristylous breeding system of *Eichhornia azurea* (Swartz) Kunth (Pontederiaceae). *Biological Journal of the Linnean Society* 77: 499–507.
- DOWNIE, S. R., S. RAMANATH, D. S. KATZ-DOWNIE, AND E. LLANAS. 1998. Molecular systematics of Apiaceae subfamily Apioideae: phylogenetic analyses of nuclear ribosomal DNA internal transcribed spacer and plastid *rpoC1* intron sequences. *American Journal of Botany* 85: 563–591.
- DOWRICK, V. P. J. 1956. Heterostyly and homostyly in *Primula obconica*. *Heredity* 10: 219–236.
- DULBERGER, R. 1992. Floral polymorphisms and their functional significance in the heterostylous syndrome. In S. C. H. Barrett [ed.], *Evolution and function of heterostyly*, 51–84. Springer-Verlag, Berlin, Germany.
- ECKERT, C. G., AND S. C. H. BARRETT. 1992. Stochastic loss of style morphs from populations of tristylous *Lythrum salicaria* and *Decodon verticillatus* (Lythraceae). *Evolution* 46: 1014–1029.
- ECKERT, C. G., AND S. C. H. BARRETT. 1995. Style morph ratios in tristylous *Decodon verticillatus* (Lythraceae): selection vs. historical contingency. *Ecology* 76: 1051–1066.
- EICHENBERGER, K., F. GUGERLI, AND J. J. SCHNELLER. 2000. Morphological and molecular diversity of Swiss common bean cultivars (*Phaseolus vulgaris* L., Fabaceae) and their origin. *Botanica Helvetica* 110: 61–77.
- ENDELS, P., H. JACQUEMYN, R. BRYN, M. HERMY, AND G. DE BLUST. 2002. Temporal changes (1986–1999) in populations of primrose (*Primula vulgaris* Huds.) in an agricultural landscape and implications for conservation. *Biological Conservation* 105: 11–25.
- ENDRESS, P. K. 1994. *Diversity and evolutionary biology of tropical flowers*. Cambridge University Press, Cambridge, UK.
- ERNST, A. 1925. Genetische Studien über Heterostylie bei *Primula*. *Archiv der Julius Klaus-Stiftung* 1: 13–62.
- ERNST, A. 1936. Weitere Untersuchungen zur Phänanalyse, zum Fertilitätsproblem und zur Genetik heterostyler Primeln. 2. *Primula hortensis* Wettstein. *Archiv der Julius Klaus-Stiftung* 11: 1–280.
- ERNST, A. 1955. Self-fertility in monomorphic primulas. *Genetica* 27: 391–448.
- ERNST, A. 1957. Austausch und Mutation im Komplex-Gen für Blütenplastik und Inkompatibilität bei *Primula*. *Zeitschrift für induktive Abstammungs- und Vererbungslehre* 88: 517–599.
- FAEGRI, K. 1986. The solanoid flower. *Transactions of the Botanical Society of Edinburgh, 150th Anniversary Supplement*: 51–59.
- FARRIS, J. S. 1989. The retention index and the rescaled consistency index. *Cladistics* 5: 417–419.
- FELSENSTEIN, J. 1985. Confidence limits on phylogenies: An approach using the bootstrap. *Evolution* 39: 783–791.
- FENDERSON, G. K. 1986. *A synoptic guide to the genus Primula*. Allen Press, Lawrence, Kansas, USA.
- FITCH, W. M. 1971. Toward defining the course of evolution: minimal change for a specific tree topology. *Systematic Zoology* 20: 406–416.
- FUJII, N., K. UEDA, Y. WATANANO, AND T. SHIMIZU. 1995. Intraspecific sequence variation in chloroplast DNA of *Primula cuneifolia* Ledeb. (Primulaceae). *Journal of Phytogeography and Taxonomy* 43: 15–24.
- FUJII, N., K. UEDA, Y. WATANANO, AND T. SHIMIZU. 1999. Further analysis of intraspecific sequence variation of chloroplast DNA in *Primula cuneifolia* Ledeb. (Primulaceae): implications for biogeography of the Japanese alpine flora. *Journal of Plant Research* 112: 87–95.

- GANDERS, F. R. 1979. The biology of heterostyly. *New Zealand Journal of Botany* 17: 607–635.
- GOULD, S. J., AND E. S. VRBA. 1982. Exaptation—a missing term in the science of form. *Paleobiology* 8: 4–15.
- GRAHAM, A. 1999. Late Cretaceous and Cenozoic history of North American vegetation. Oxford University Press, Oxford, UK.
- GRAY, A. 1886. Essay toward a revision of *Dodecatheon*. *Botanical Gazette* 11: 231–234.
- HALDA, J. J. 1992. The genus *Primula* in cultivation and the wild. Tethys Books, Denver, Colorado, USA.
- HALL, H. M. 1901. Studies on Californian plants. I. *Botanical Gazette* 31: 388–393.
- HALL, H. M. 1912. New and noteworthy Californian plants. I. *University of California Publications in Botany* 4: 195–208.
- HAMILTON, M. B. 1999. Four primer pairs for the amplification of chloroplast intergenic regions with intraspecific variation. *Molecular Ecology* 8: 521–523.
- HARDER, L. D., AND R. M. R. BARCLAY. 1994. The functional significance of poricidal anthers and buzz pollination: controlled pollen removal from *Dodecatheon*. *Functional Ecology* 8: 509–517.
- HARDER, L. D., AND J. D. THOMSON. 1989. Evolutionary options for maximizing pollen dispersal of animal-pollinated plants. *American Naturalist* 133: 323–344.
- HARDER, L. D., AND W. G. WILSON. 1994. Floral evolution and male reproductive success: optimal dispensing schedules for pollen dispersal by animal-pollinated plants. *Evolutionary Ecology* 8: 542–559.
- HARRIS, S. A., AND R. INGRAM. 1991. Chloroplast DNA and biosystematics: the effects of interspecific diversity and plastid transmission. *Taxon* 40: 393–412.
- HASEGAWA, M., H. KISHINO, AND T. YANO. 1985. Dating of the human–ape splitting by a molecular clock of mitochondrial DNA. *Journal of Molecular Evolution* 21: 160–174.
- HOLMGREN, N. H. 1994. Redefinition of *Dodecatheon dentatum* (Primulaceae) and rationale for use of varietal rank. *Brittonia* 46: 87–94.
- HOLMGREN, N. H., AND S. K. KELSO. 2001. *Primula cusickiana* (Primulaceae) and its varieties. *Brittonia* 53: 154–156.
- HUELSENBECK, J. P., AND F. RONQUIST. 2001. MRBAYES: Bayesian inference of phylogenetic trees. *Bioinformatics* 17: 754–755.
- HULTÉN, E. 1968. Flora of Alaska and neighboring territories: a manual of the vascular plants. Stanford University Press, Stanford, California, USA.
- HUSBAND, B. C., AND S. C. H. BARRETT. 1992. Genetic drift and the maintenance of the style polymorphism in tristylous populations of *Eichhornia paniculata* (Pontederiaceae). *Heredity* 69: 440–449.
- JORDAN, W. C., M. W. COURTNEY, AND J. E. NEIGEL. 1996. Low levels of intraspecific genetic variation at a rapidly evolving chloroplast DNA locus in North American duckweeds (Lemnaceae). *American Journal of Botany* 83: 430–439.
- KÄLLERSJÖ, M., G. BERGQVIST, AND A. A. ANDERBERG. 2000. Generic realignment in primuloid families of the Ericales s.l.: a phylogenetic analysis based on DNA sequences from three chloroplast genes and morphology. *American Journal of Botany* 87: 1325–1341.
- KELSO, S. 1991. Taxonomy and biogeography of *Primula* sect. *Cuneifolia* (Primulaceae) in North America. *Madroño* 38: 37–44.
- KLUGE, A. G., AND J. S. FARRIS. 1969. Quantitative phyletics and the evolution of anurans. *Systematic Zoology* 18: 1–32.
- KURIAN, V., AND A. J. RICHARDS. 1997. A new recombinant in the heteromorphy ‘S’ supergene in *Primula*. *Heredity* 78: 383–390.
- LEEGE, L. M., AND L. M. WOLFE. 2002. Do floral herbivores respond to variation in flower characteristics in *Gelsemium sempervirens* (Loganiaceae), a distylous vine? *American Journal of Botany* 89: 1270–1274.
- LEWIS, D. 1949. Incompatibility in flowering plants. *Biological Review* 24: 472–496.
- LEWIS, D., AND D. A. JONES. 1992. The genetics of heterostyly. In S. C. H. Barrett [ed.], *Evolution and function of heterostyly*. Springer-Verlag, Berlin, Germany.
- MACIOR, L. W. 1964. Experimental study of floral ecology of *Dodecatheon meadia*. *American Journal of Botany* 51: 96–108.
- MACIOR, L. W. 1970. Pollination ecology of *Dodecatheon amethystinum* (Primulaceae). *Bulletin of the Torrey Botanical Club* 97: 150–153.
- MAL, T. K., AND J. LOVETT-DOUST. 1997. Morph frequencies and floral variation in a heterostylous colonizing weed, *Lythrum salicaria*. *Canadian Journal of Botany* 75: 1034–1045.
- MARTINS, L., C. OBERPRIELER, AND F. H. HELLMIG. 2003. A phylogenetic analysis of Primulaceae s.l. based on internal transcribed spacer (ITS) DNA sequence data. *Plant Systematics and Evolution* 237: 75–85.
- MAST, A. R., S. K. KELSO, A. J. RICHARDS, D. J. LANG, D. M. S. FELLER, AND E. CONTI. 2001. Phylogenetic relationships in *Primula* L. and related genera (Primulaceae) based on noncoding chloroplast DNA. *International Journal of Plant Sciences* 162: 1381–1400.
- MCDADE, L., AND M. L. MOODY. 1999. Phylogenetic relationships among Acanthaceae: evidence from noncoding *trnL-trnF* chloroplast DNA sequences. *American Journal of Botany* 86: 70–80.
- MOORE, P. D., J. A. WEBB, AND M. E. COLLINSON. 1991. Pollen analysis, 2nd ed. Blackwell Scientific Publications, Oxford, UK.
- MORGENSON, H. L. 1996. The hows and whys of cytoplasmic inheritance in seed plants. *American Journal of Botany* 83: 383–404.
- MULLIS, K. B., AND F. A. FALOONA. 1987. Specific synthesis of DNA in vitro via a polymerase catalyzed chain reaction. *Methods in Enzymology* 155: 335–350.
- OLESEN, J. M. 1979. Differential anther eating by snails in the heterostylous plant species, *Primula elatior* (L.) Hill. *Acta Botanica Neerlandica* 28: 519–521.
- OXELMAN, B., M. LIDÉN, AND D. BERGLUND. 1997. Chloroplast *rps16* intron phylogeny of the tribe Sileneae (Caryophyllaceae). *Plant Systematics and Evolution* 206: 393–410.
- PIPER, J., AND B. CHARLESWORTH. 1986. The evolution of distyly in *Primula vulgaris*. *Biological Journal of the Linnean Society* 29: 123–137.
- POSADA, D., AND K. A. CRANDALL. 1998. Modeltest: testing the model of DNA substitution. *Bioinformatics* 14: 817–818.
- PRAGER, E. M., AND A. C. WILSON. 1988. Ancient origin of lactalbumin from lysozyme: analysis of DNA and amino acid sequences. *Journal of Molecular Evolution* 27: 326–335.
- RICHARDS, A. J. 1993. *Primula*, 1st ed. Timber Press, Portland, Oregon, USA.
- RICHARDS, A. J. 1997. Plant breeding systems. Chapman & Hall, London, UK.
- RICHARDS, A. J. 1998. Lethal linkage and its role in the evolution of plant breeding systems. In S. J. Owens and P. J. Rudall [eds.], *Reproductive biology*, 71–83. Royal Botanic Gardens, Kew, UK.
- RICHARDS, A. J. 2002. *Primula*, 2nd ed. B. T. Batsford, London, UK.
- ROBERTS, R. B. 1969. Biology of the bee genus *Agapostemon* (Hymenoptera: Halictidae). *University of Kansas Science Bulletin* 48: 689–719.
- SANG, T., D. J. CRAWFORD, AND T. F. STUESSY. 1997. Chloroplast DNA phylogeny, reticulate evolution, and biogeography of *Paeonia* (Paeoniaceae). *American Journal of Botany* 84: 1120–1136.
- SHIMODAIRA, H., AND M. HASEGAWA. 1999. Multiple comparisons of log-likelihoods with applications to phylogenetic inference. *Molecular Biology and Evolution* 16: 1114–1116.
- SMALL, R. L., J. A. RYBURN, R. C. CRONN, T. SEELANAN, AND J. F. WENDEL. 1998. The tortoise and the hare: choosing between noncoding plastome and nuclear *adh* sequences for phylogeny reconstruction in a recently diverged plant group. *American Journal of Botany* 85: 1301–1315.
- SMITH, W. W., AND H. R. FLETCHER. 1942. The genus *Primula*: sections *Amethystina*, *Minutissima*, *Bella*, *Muscarioides*. *Transactions and Proceedings of the Botanical Society of Edinburgh* 33: 209–294.
- SMITH, W. W., AND H. R. FLETCHER. 1950. Additions and corrections to the genus *Primula* (up to and including 1949). *Transactions and Proceedings of the Botanical Society of Edinburgh* 35: 180–202.
- SOLTIS, P. S., AND D. E. SOLTIS. 2000. The role of genetic and genomic attributes in the success of polyploids. *Proceedings of the National Academy of Science* 97: 7051–7057.
- SUTTILL, T. A., AND G. A. ALLEN. 1992. Morphological and chromosomal variation in *Dodecatheon pulchellum* (Primulaceae). *Canadian Journal of Botany* 70: 2476–2483.
- SWOFFORD, D. L. 2002. PAUP\*. Phylogenetic analysis using parsimony (\*and other methods), Version 4b10. Sinauer, Sunderland, Massachusetts, USA.
- TABERLET, P., L. GIELLY, G. PAUTOU, AND J. BOUVET. 1991. Universal primers for amplification of three non-coding regions of chloroplast DNA. *Plant Molecular Biology* 17: 1105–1109.
- THOMPSON, F. L., L. A. HERMANUTZ, AND D. J. INNES. 1998. The reproductive ecology of island populations of distylous *Menyanthes trifoliata* (Menyanthaceae). *Canadian Journal of Botany* 76: 818–828.
- THOMPSON, H. J. 1953. The biosystematics of *Dodecatheon*. *Contributions from the Dudley Herbarium* 4: 73–154.
- TRIFT, I., M. KÄLLERSJÖ, AND A. A. ANDERBERG. 2002. The monophyly of

- Primula* (Primulaceae) evaluated by analysis of sequences from the chloroplast gene *rbcL*. *Systematic Botany* 27: 396–407.
- VOGEL, S. 1978. Evolutionary shifts from reward to deception in pollen flowers. In A. J. Richards [ed.], *The pollination of flowers by insects*, 89–96. Academic Press, London, UK.
- VOGEL, S. 1986. Oelblumen und olsammelnde Bienen. Zweite Folge. *Lysimachia* und *Macropis*. *Tropische und subtropische Pflanzenwelt* 54: 1–168.
- WASHITANI, I. 1996. Predicted genetic consequences of strong fertility selection due to pollinator loss in an isolated population of *Primula sieboldii*. *Conservation Biology* 10: 59–64.
- WEBB, C. J., AND D. G. LLOYD. 1986. The avoidance of interference between the presentation of pollen and stigmas in angiosperms II. Herkogamy. *New Zealand Journal of Botany* 24: 163–178.
- WEBSTER, M. A., AND P. M. GILMARTIN. 2003. A comparison of early floral ontogeny in wild-type and floral homeotic mutant phenotypes of *Primula*. *Planta* 216: 903–917.
- WEDDERBURN, F., AND A. J. RICHARDS. 1990. Variation in within morph incompatibility inhibition sites in heteromorphic *Primula* L. *New Phytologist* 116: 149–162.
- WEDDERBURN, F. M., AND A. J. RICHARDS. 1992. Secondary homostyly in *Primula* L.: evidence for the model of the S-supergene. *New Phytologist* 121: 649–655.
- WENDELBO, P. 1961a. Studies in Primulaceae II: an account of *Primula* subgenus *Sphondylia* (syn. sect. *Floribundae*) with a review of the subdivisions of the genus. *Arbok for Universitetet I Bergen, Mathematica-Naturalium* 11: 1–46.
- WENDELBO, P. 1961b. Studies in Primulaceae III: on the genera related to *Primula* with special reference to their pollen morphology. *Arbok for Universitetet I Bergen, Mathematica-Naturalium* 19: 1–31.
- ZHANG, L.-B. 2002. Phylogeny, biogeography and systematics of *Soldanella* L. and *Primula* L. sect. *Auricula* Duby (Primulaceae) based on molecular and morphological evidence. Cuvillier Verlag, Göttingen, Germany.
- ZHARKIKH, A. 1994. Estimation of evolutionary distances between nucleotide sequences. *Journal of Molecular Evolution* 39: 315–329.